

Geenitekniikan menetelmiä ja sovelluksia opettajille 10/2023

Kirimo Wartiovaara

LT, dosentti, Helsingin yliopisto

perinnöllisyyslääketieteen erikoislääkäri, HUS

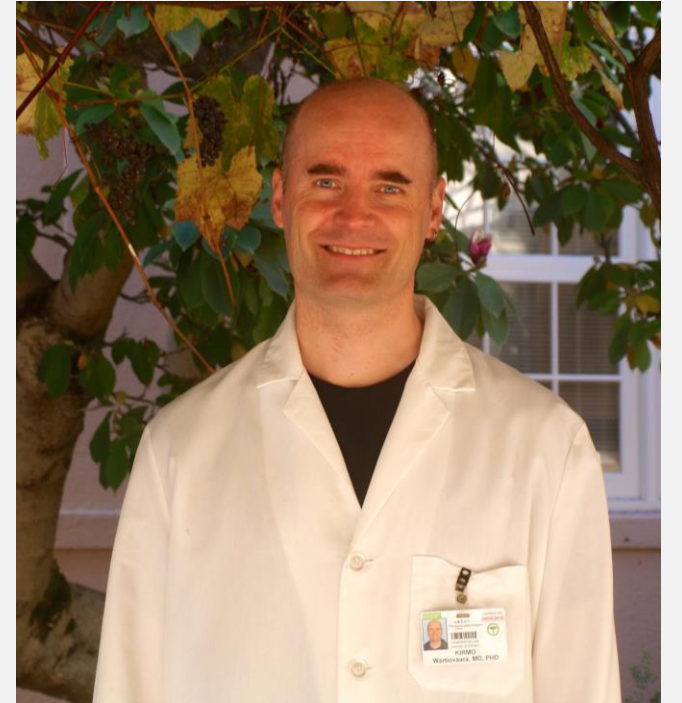

Toiveita luennoille:

- mitä menetelmiä oikeasti käytetään, mihin tarkoitukseen ja miten
- mihin crispriä käytetään
- mitä dna-siruilla tehdään, vai onko sekvensointi jo korvannut ne
- geenitekniikan lääketieteelliset sovellukset, geenihoito
- mitä kuuluu kantasolututkimukselle

BIOL6: DNA:n muokkaus ja tutkiminen geenitekniikalla, Biotekniikan keskeiset sovellukset ja merkitys

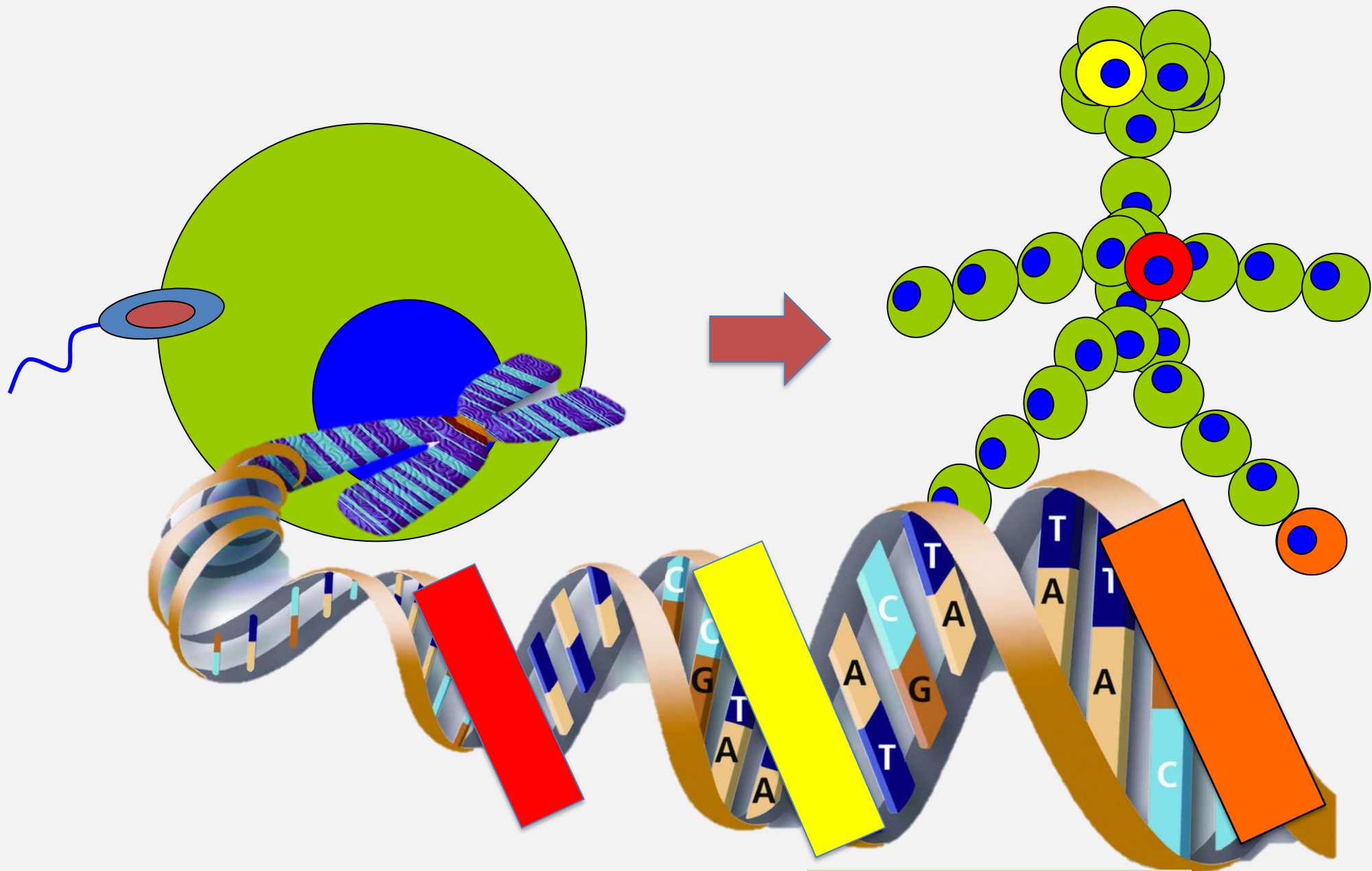

GEENI= RESEPTI

DNA= KIRJAIMET

Elämän puu

Animals

You are here

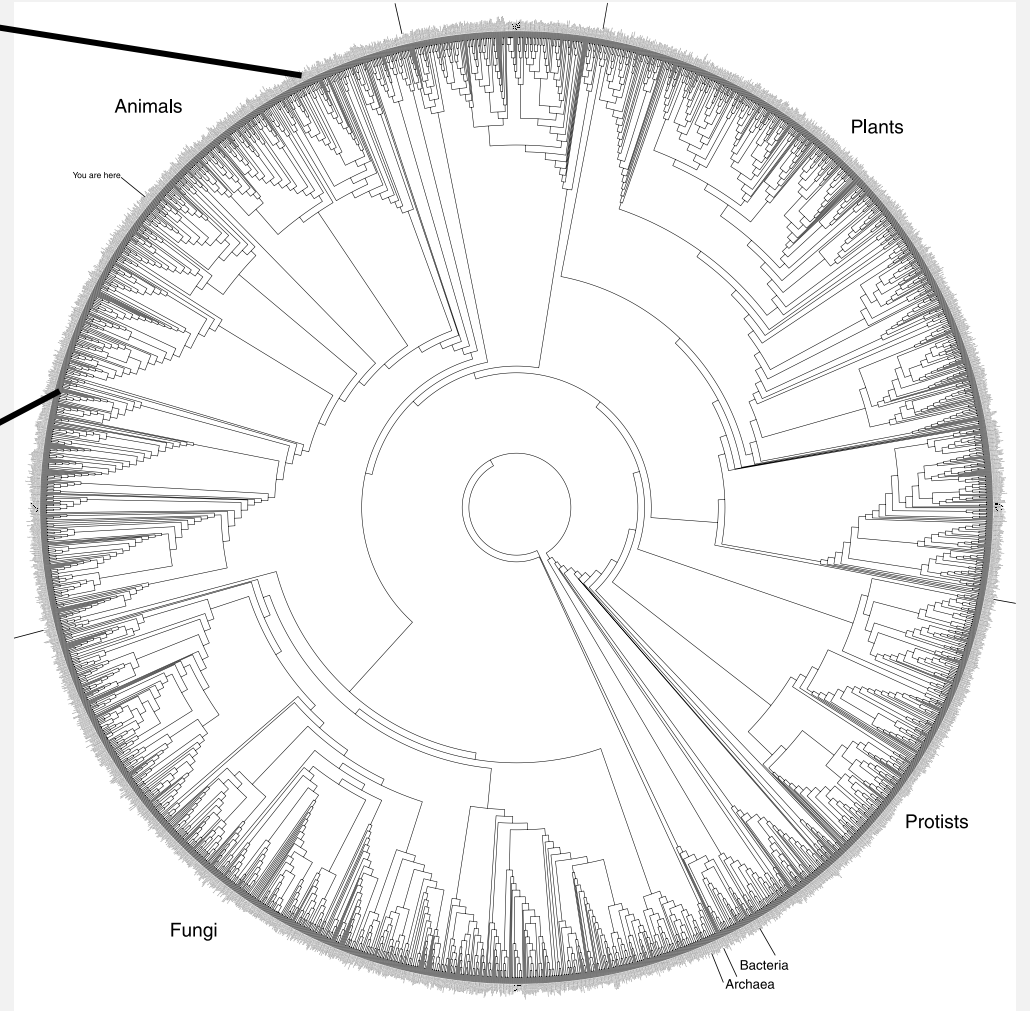
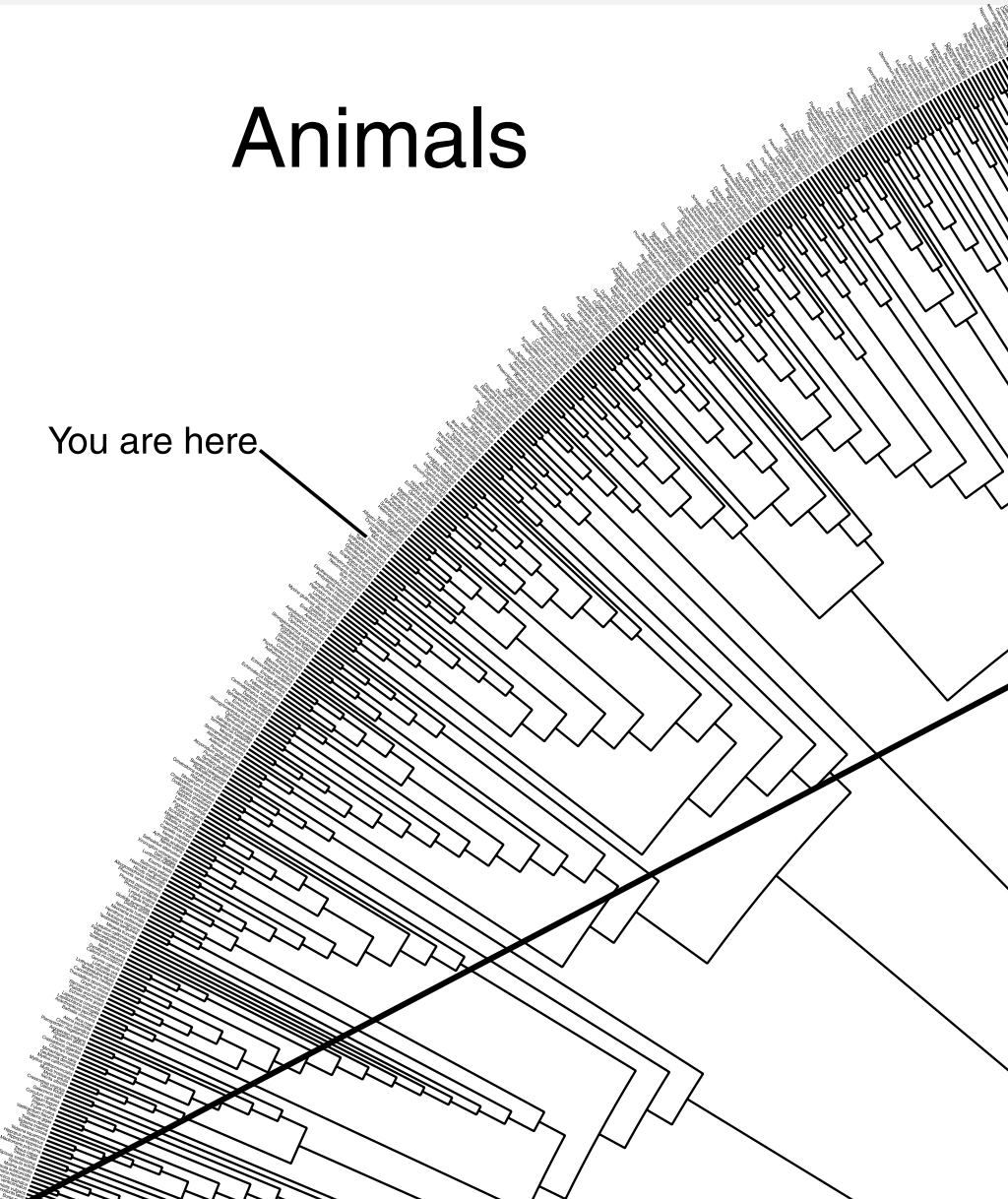

David M. Hillis, Derrick Zwickl, Robin Gutell, University of Texas. Analysis of small subunit rRNA sequences from about 3,000 species

Ihmiskunnan DNA – elämän koodin kirjoitus

Kirmo Wartiovaara

LT, dosentti, Helsingin yliopisto

Perinnöllisyyslääketieteen erikoislääkäri, HUS

Kustannustoimittaja: Ulla Gröhn
Kansi: Sanna-Reeta Meilahti
Valokuva: Heidihanna Karhu
Sisuksen taittomalli: Sanna-Reeta Meilahti
Piirokset: Pirkko Linkola
Taitto: Harri Tienhaara

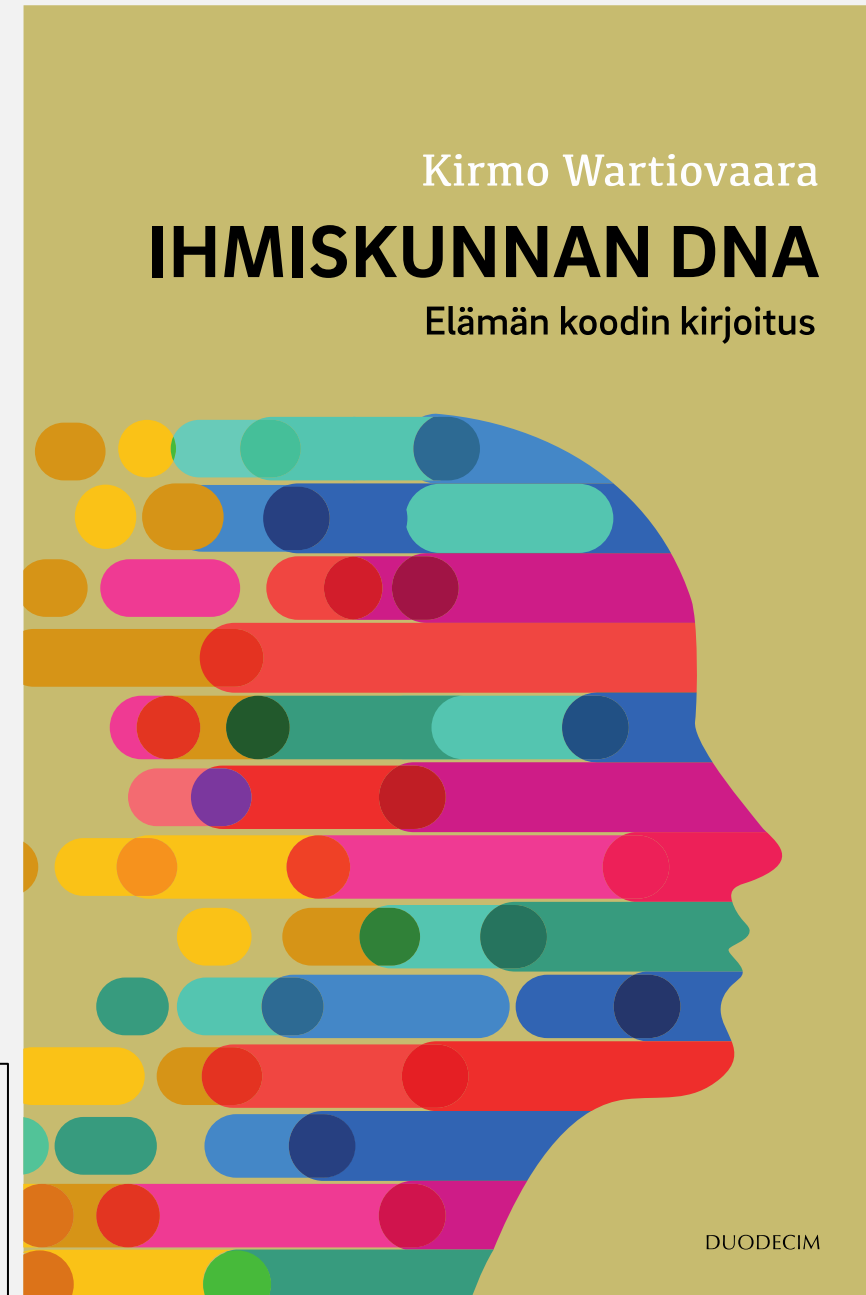

Ihmiskunnan DNA –elämän koodin kirjoitus

1. Biologian/lääketieteen kysymys: mitä DNA:ssa lukee? *Mitkä muutokset ovat hyviä ihmiselle/muille eliöille/maapallolle?*
2. (Bio)tekninen kysymys: miten DNA:ta muokataan? *Parhaat tekniikat? Uudet osaamisalueet, kuten epigenetiikka?*
3. Yhteiskunnallinen kysymys: miten DNA:n lukeminen tai muokkaus voi vaikuttaa ihmisiin? *Mitä saa tehdä? Kuka päättää?*

*”Tieteellinen edistys riippuu uusista tekniikoista,
löydöistä ja ideoista, luultavasti tässä
järjestyksessä.”*

-Nobelisti Sydney Brenner

Osa 1. Mitä DNA:ssa lukee?

PCR ja kloonauus

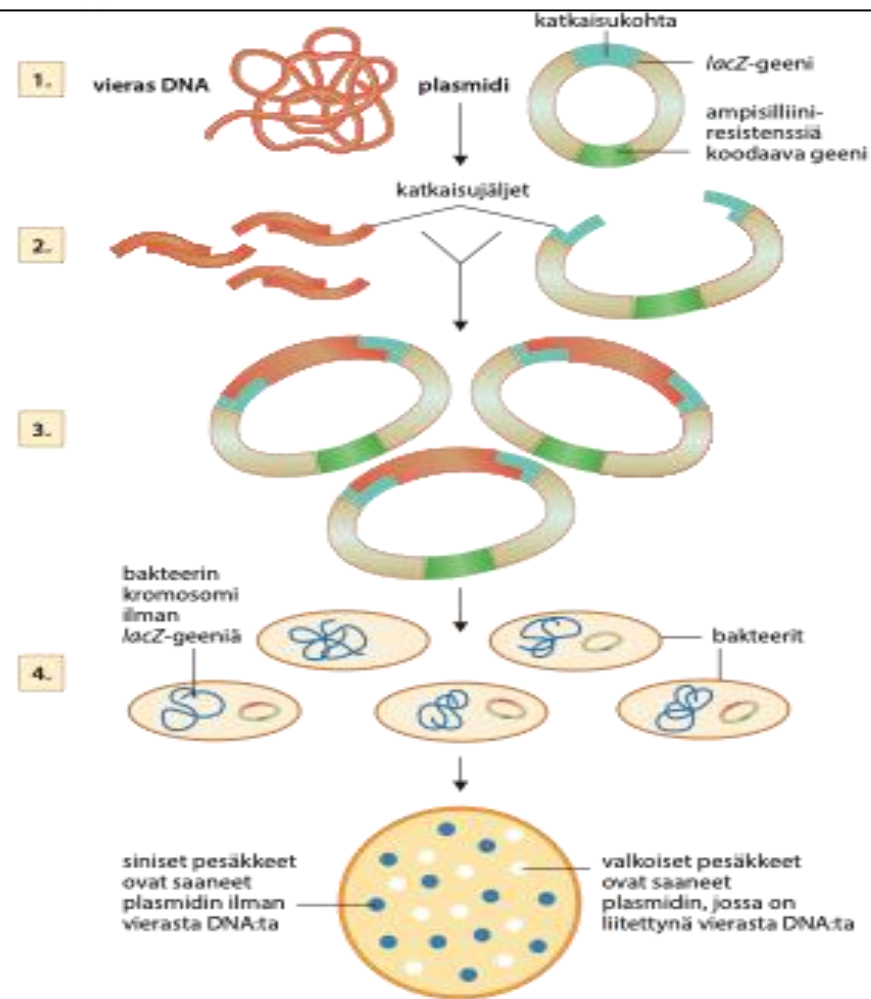
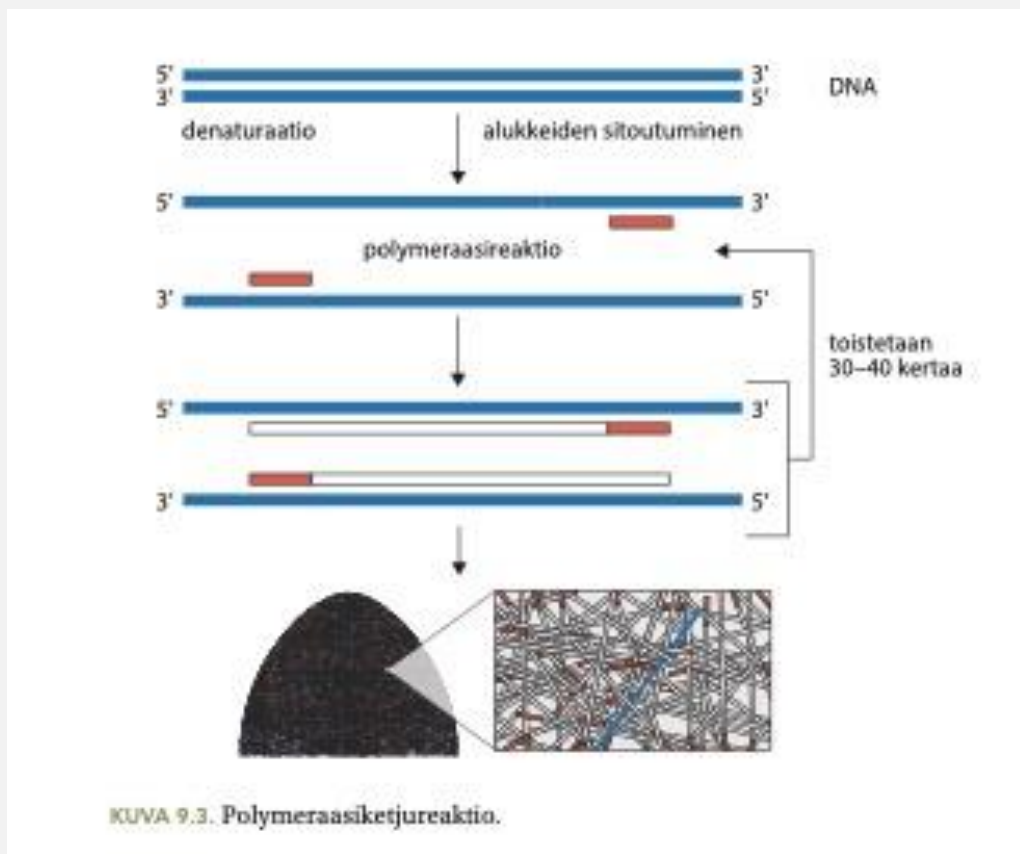
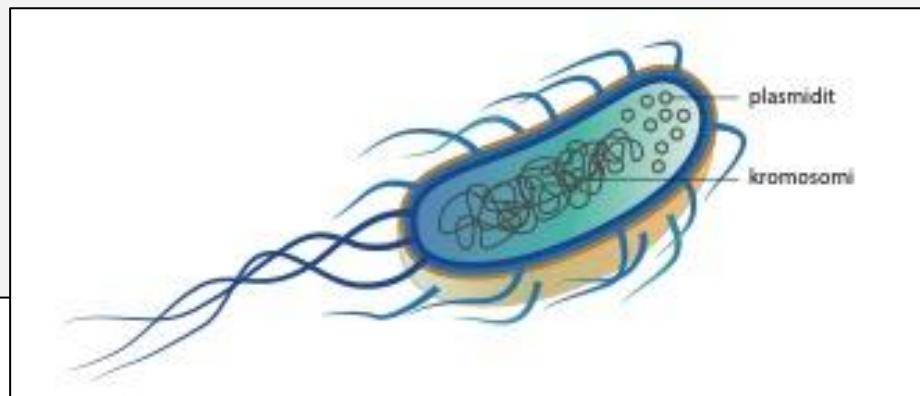

SANGER

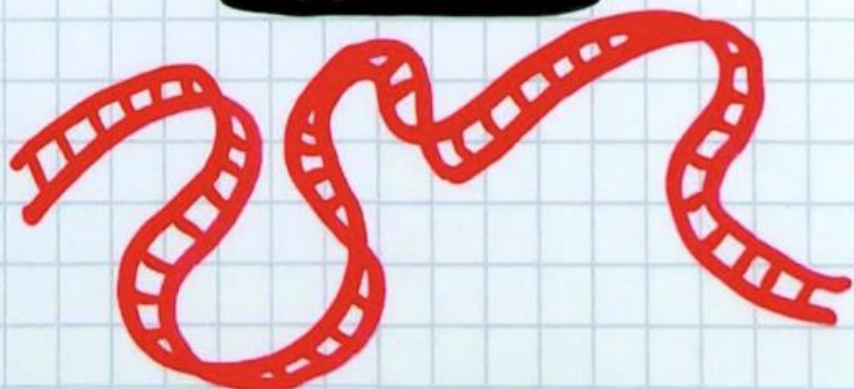
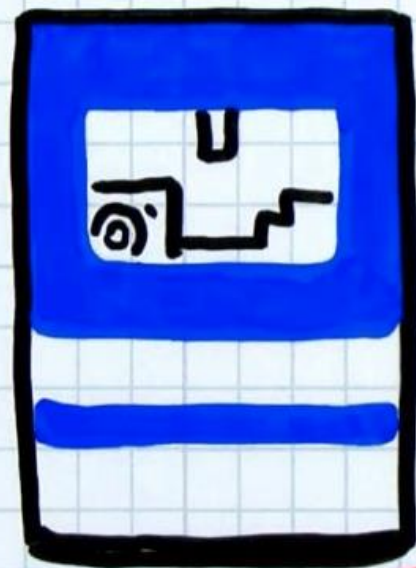

NGS

MASSIVELY
PARALLEL

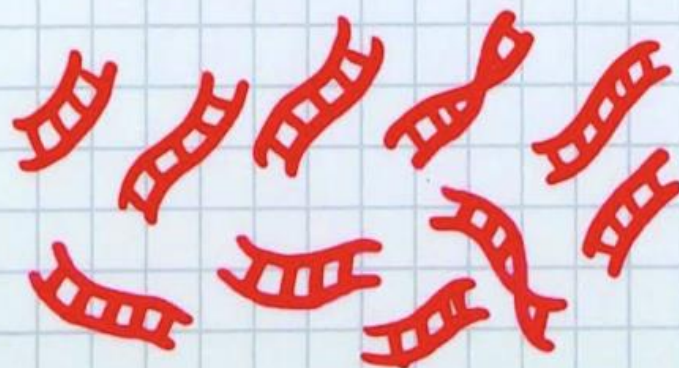
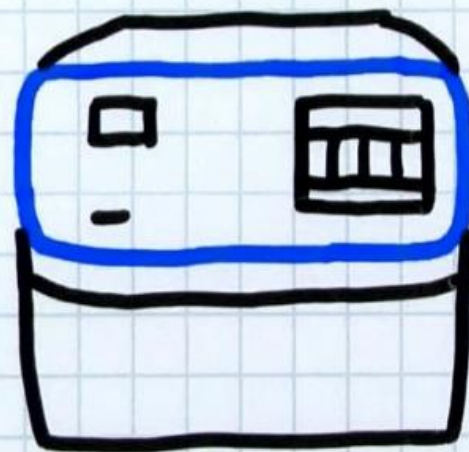

Sirutekniikan periaate

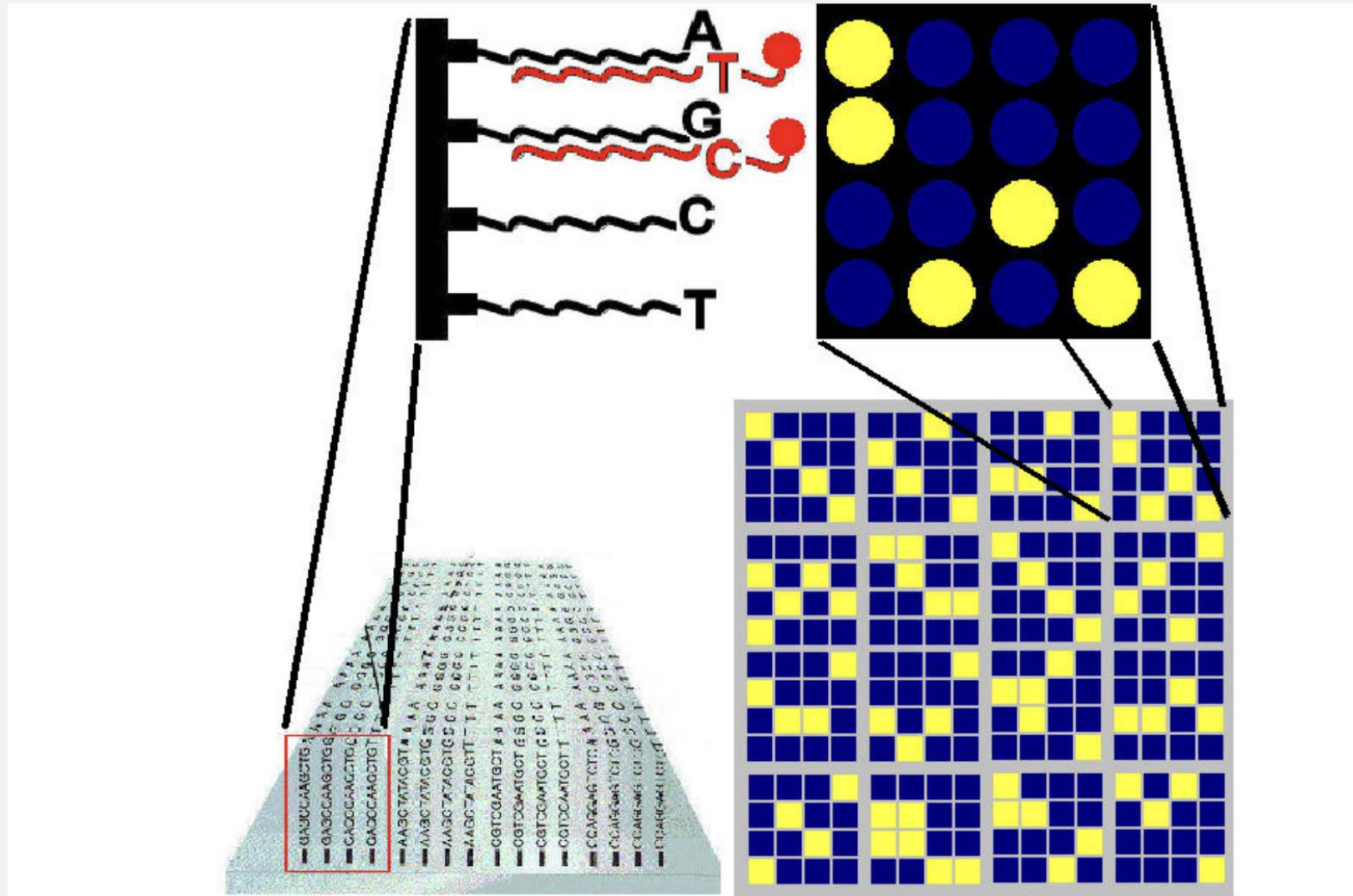

Principle of a **DNA microarray chip**: use as **Variant Detector Arrays (VDAs)**

(after SM Carr *et al.* 2008. *Comp Biochem Physiol D*, 3:11)

Periytyminen

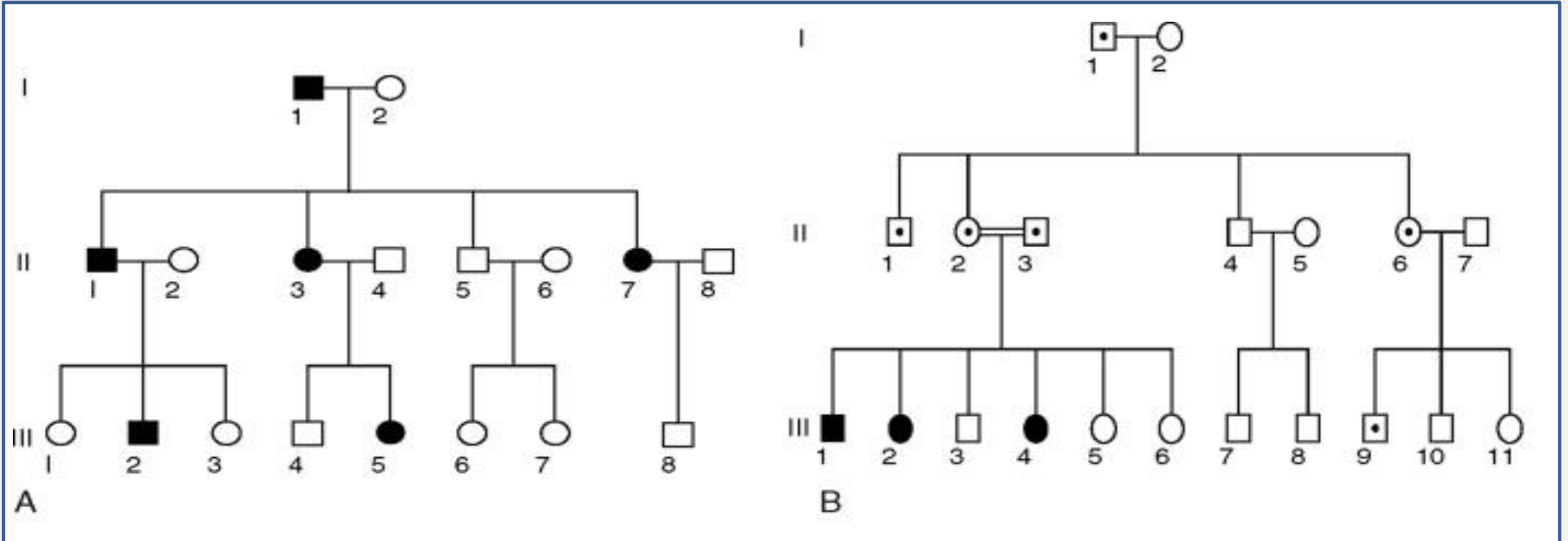

Vallitseva

Peittyvä

Ihmisen perimän vaihtelun suuruusluokat

Ihmisen koko perimä: noin kolme miljardia emästä

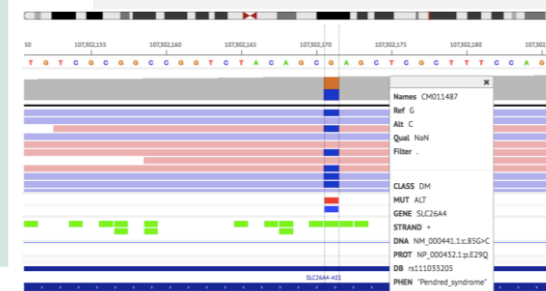
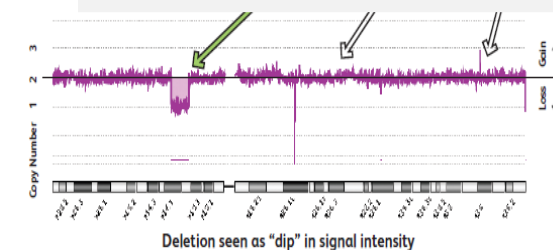
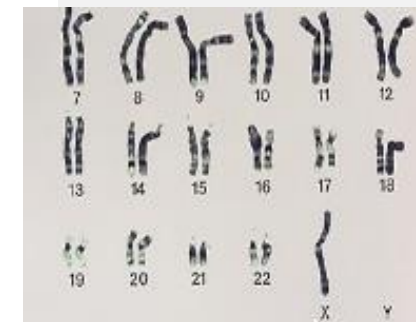
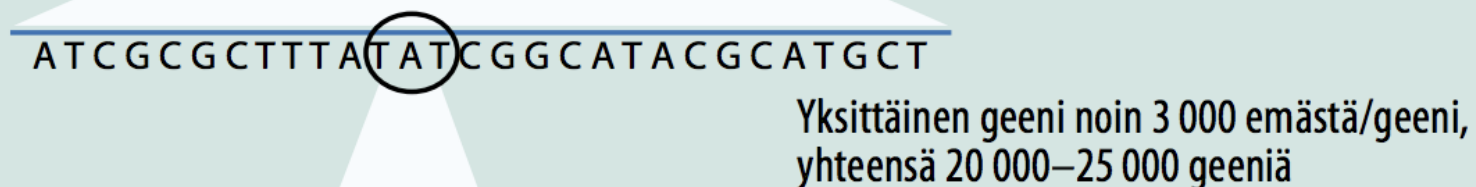
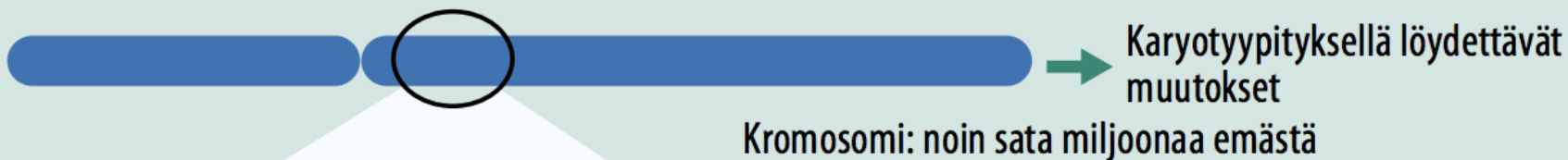

KUVA 1. Ihmisen perimässä on monenlaista vaihtelua. Osa vaihtelusta kohdistuu kokonaiseen kromosomiin (trisomiat, Turnerin oireyhtymä) tai kromosomin rakenteen muutokseen. Osa vaihtelusta on pienemmän kromosomin osan deleetioita tai duplikaatioita (kopiolukumuutokset). Pienimmillään muutos voi olla vain yhden emäksen vaihtuminen toiseksi tai yhden emäksen deleetio tai duplikaatio.

Diagnostisten geenitutkimusten valikoima kasvaa

Genetic test registry:

55 303 tests

11 174 conditions

5 390 genes

510 labs

ORPHANET:

Diseases 5,856

Genes 3,573

Expert centres 7,135 Diagnostic tests

40,720 Laboratories 3,367

Professionals 20,739

GTR Data

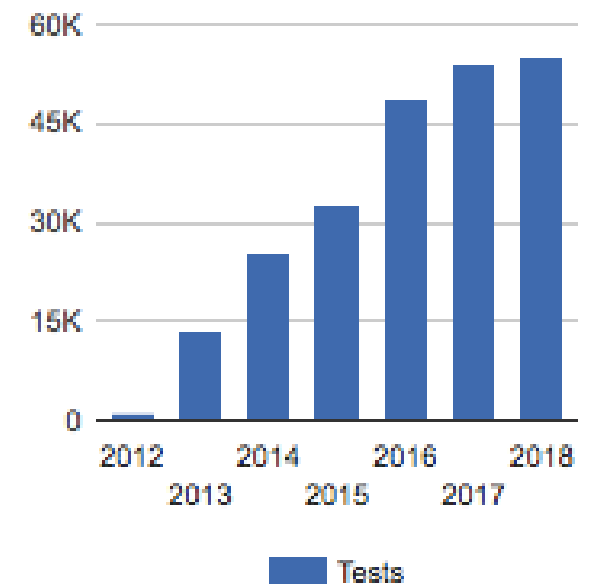
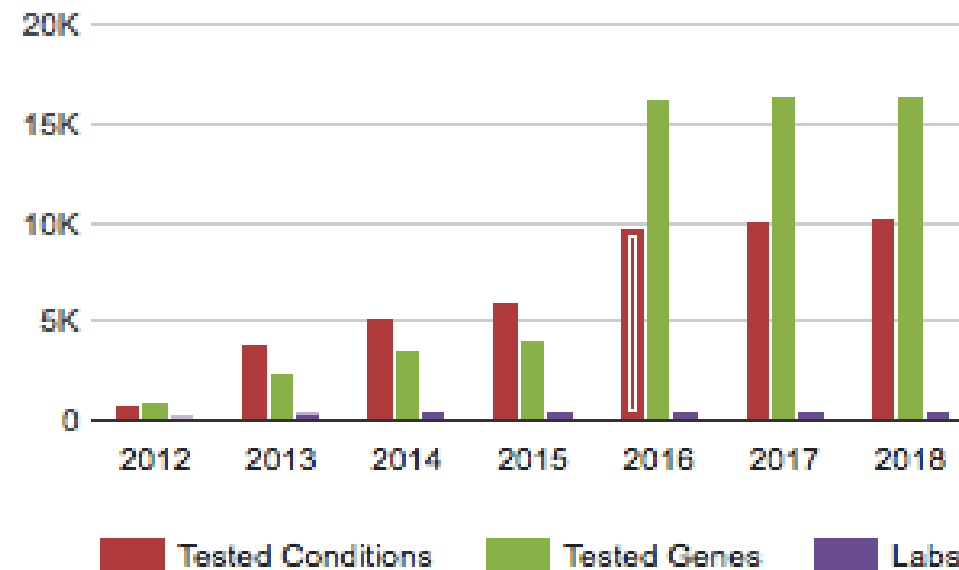

[FTP: Download GTR data and documents](#)

Mihin geenitutkimuksia käytetään?

- diagnoosin varmistukseen
- ennustava diagnostiikka
 - esim. syöpäsairaudet, aikuisiällä alkavat taudit
- kantajuustutkimukset (perhesuunnittelu)
- sikiödiagnostiikka

- Farmakogenetiikka, personalised medicine
 - annostarve, herkkyys vakaville haittavaikutuksilla

(Oikeuslääketiede, oikeusgeneettiset isyystutkimukset)

Eron hetki

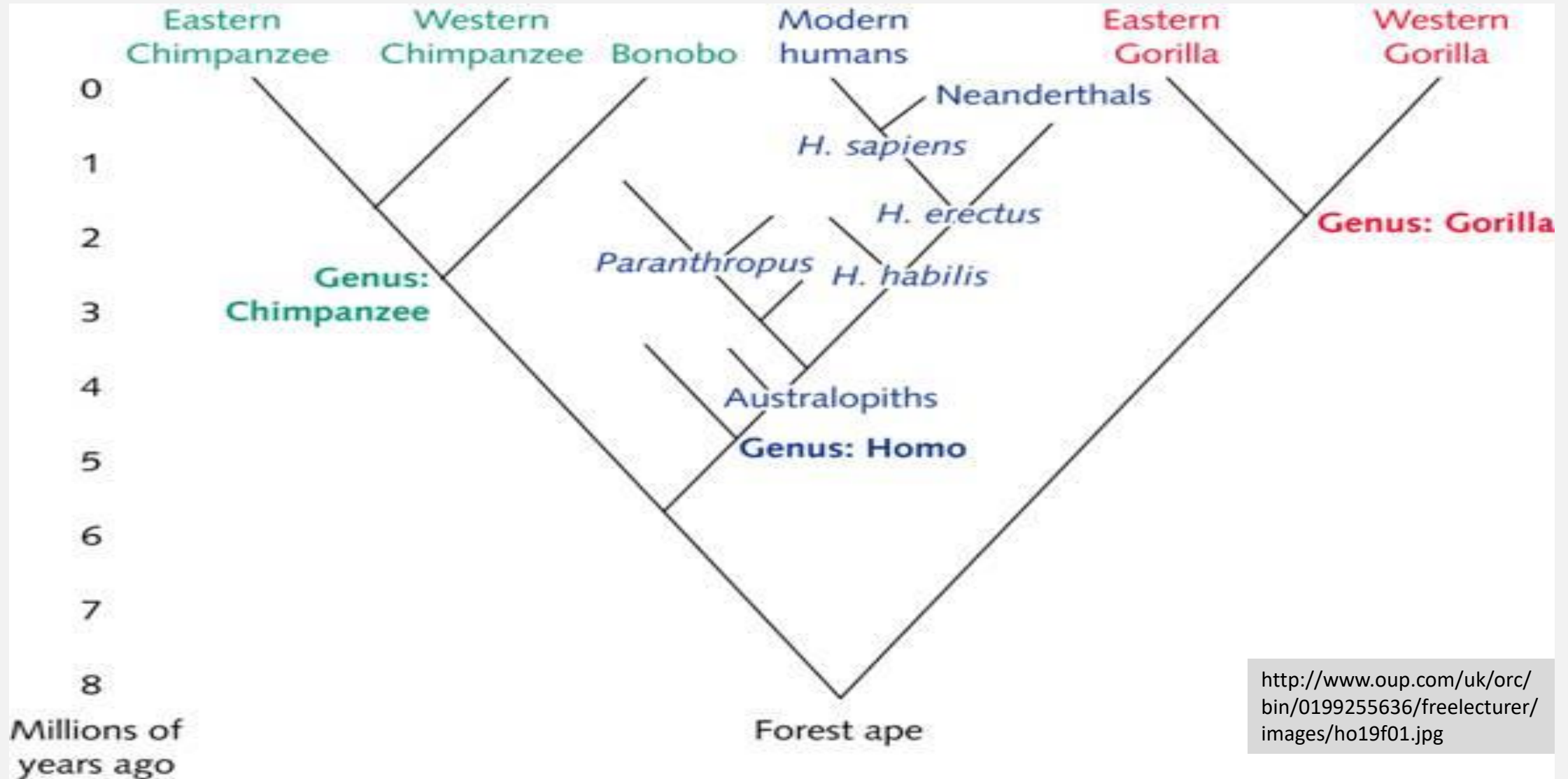

Simpanssin ja ihmisen kromosomit

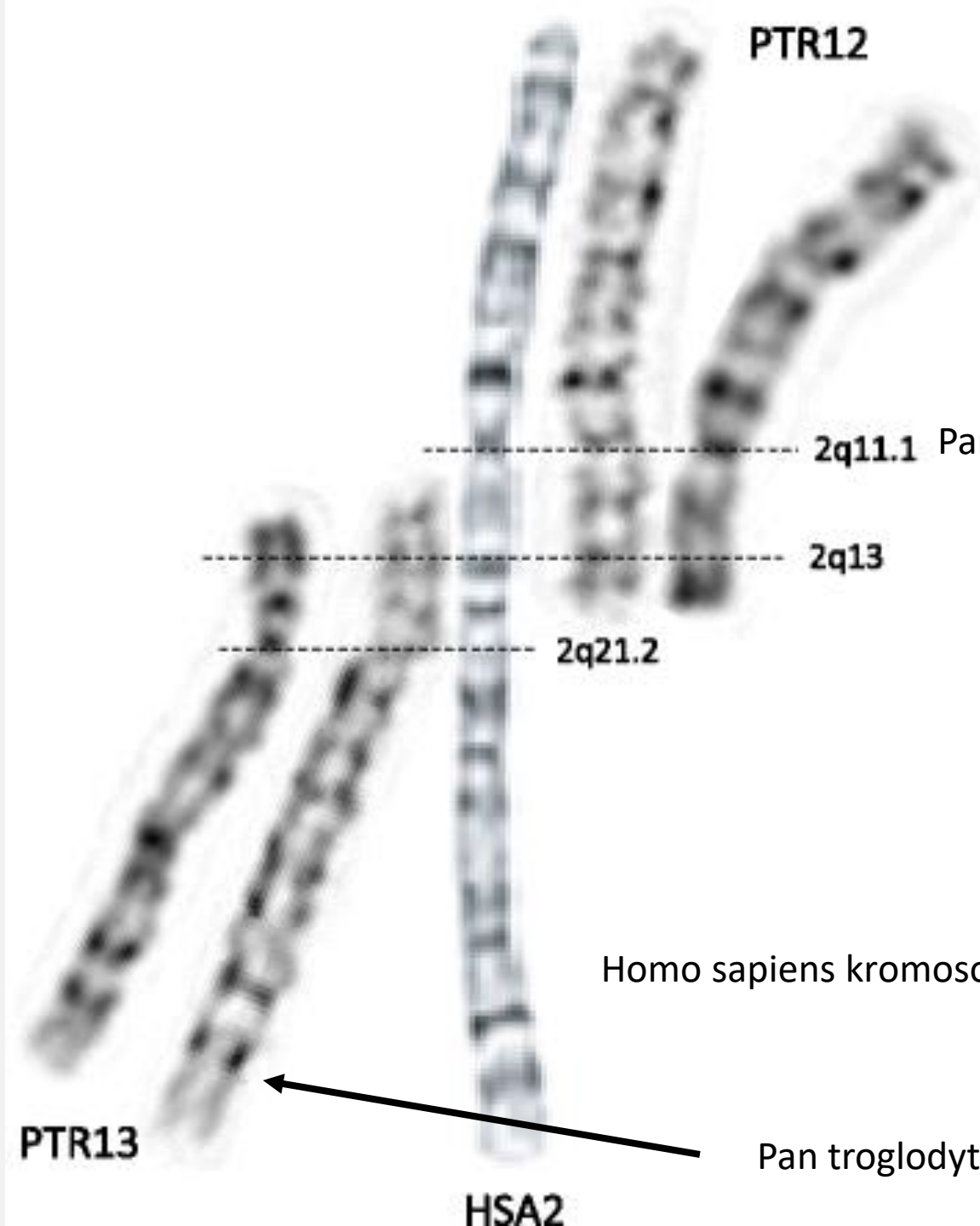

2q11.1 Pan troglodytes (simpanssi) kromosomi 12

2q13

2q21.2

Homo sapiens kromosome 2

PTR13

HSA2

Pan troglodytes (simpanssi) kromosomi 13

Stankiewicz, P. One pedigree we all may have come from – did Adam and Eve have the chromosome 2 fusion?. *Mol Cytogenet* **9**, 72 (2016).
<https://doi.org/10.1186/s13039-016-0283-3>

The longest series of human generations originates in Africa

- Homo sapiens
- Homo neanderthalensis
- Homo erectus

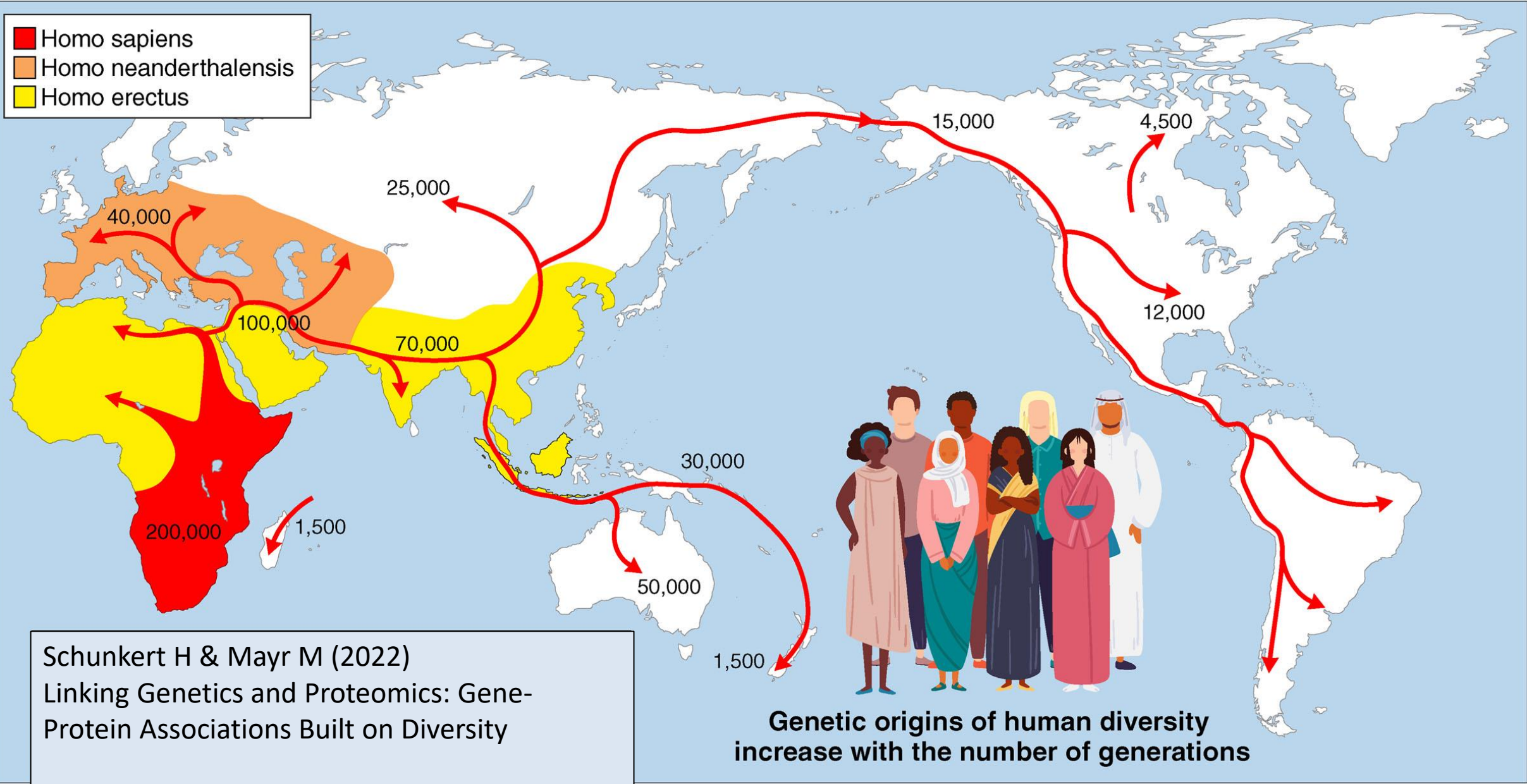

Schunkert H & Mayr M (2022)
Linking Genetics and Proteomics: Gene-Protein Associations Built on Diversity
Circulation. 145:371–374

Genetic origins of human diversity increase with the number of generations

Osa 2 Miten DNA:ta muutetaan ?

1. valikointi eli niiden yksilöiden suvun jatkaminen, joilla on hyviä ominaisuuksia
2. mutaatiojalostus eli muutosten määrän lisääminen keinotekoisesti valikointia varten
3. risteyttäminen, jossa yhdistetään hyviä ominaisuuksia eri yksilöistä
4. geeninsiirto eli ulkopuolelta tuotavan geenin liittäminen tilapäisesti tai pysyvästi
5. geenimuokkaus eli solussa jo olemassa olevan geenin suunnitelmallinen muuttaminen

Tietokilpailukysymys: kenen voidaan sanoa pelastaneen miljardi ihmistä kuolemalta?



Norman E. Borlaug (1914–2009)

GEENITERAPIA

“perinteinen”

Tavoite: terapeuttisten geenien ilmentäminen väliaikaisesti tai pysyvästi

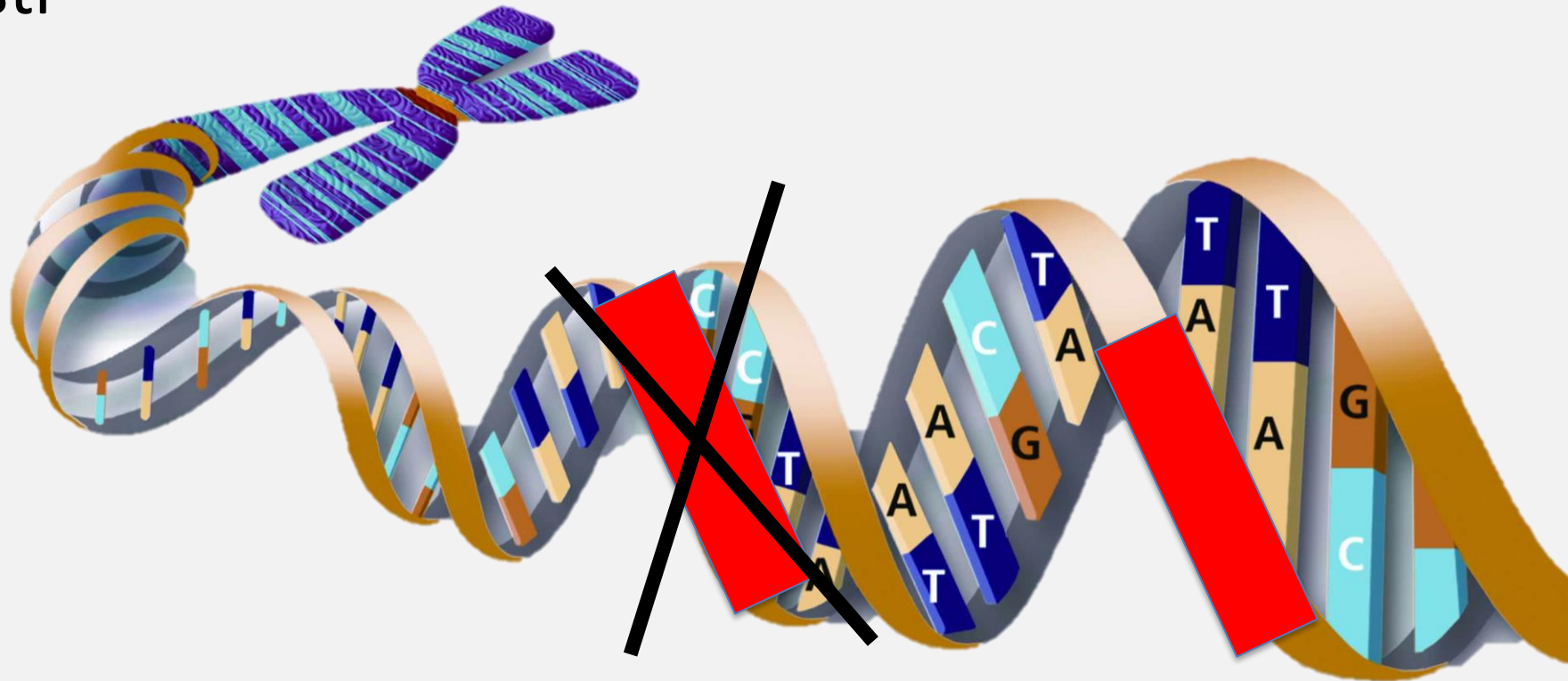

GEENINSIIRTO

Tavoite: Hyödyllisten geenien ilmentäminen väliaikaisesti tai pysyvästi

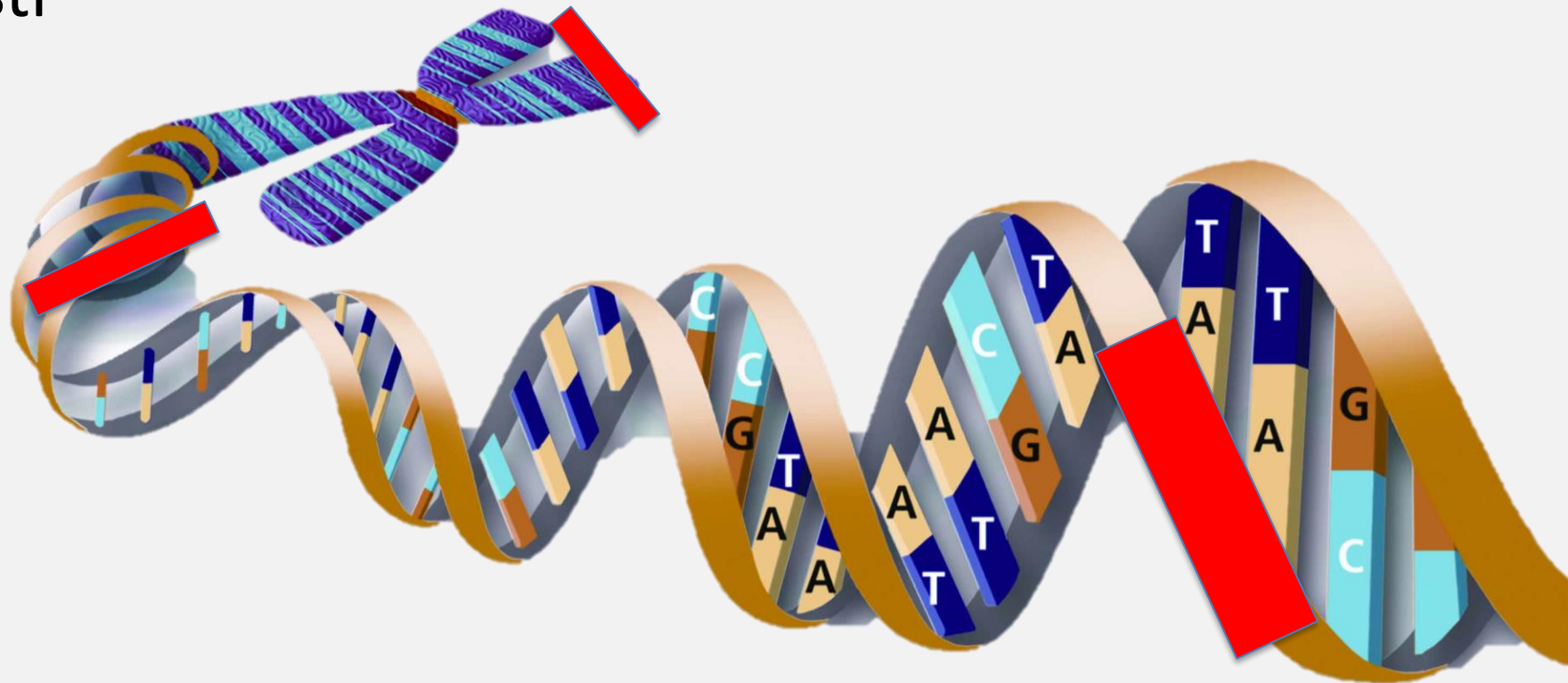

CHIMERIC ANTIGEN RECEPTOR T-CELL (CAR-T)

BUILDING A BETTER T-CELL: By modifying T cells to express chimeric antigen receptors (CARs) that recognize cancer-specific antigens, researchers can prime the cells to recognize and kill tumor cells that would otherwise escape immune detection. The process involves extracting a patient's T cells, transfecting them with a gene for a CAR, then reinfusing the transfected cells into the patient.

© LUCY READING-IKKANDA/www.the-scientist.com

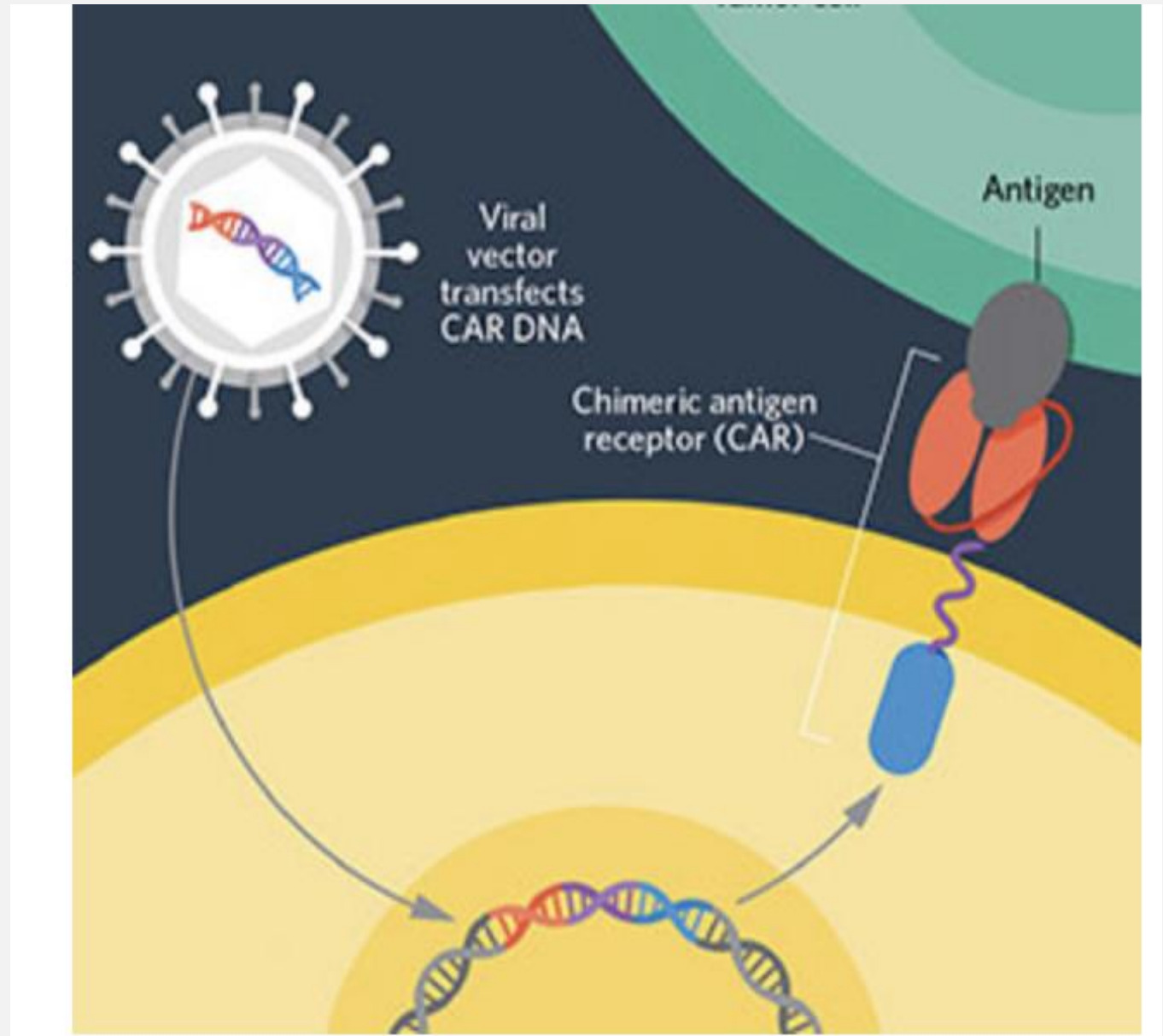

Gene therapy trials VIII/2023



The U.S. government does not review or approve the safety and science of all studies listed on this website.

Read our full [disclaimer](#) for details.



Focus Your Search (all filters optional)

Hide
◀

Condition or disease ⓘ

Other terms ⓘ

Clear Filters (1)

Apply Filters

Search Results

Card View

Table View

Viewing 1-10 out of **10,495 studies**

Selected (0)

Download

● COMPLETED

NCT00427726

Follow-up of Breast Cancer and Multiple Myeloma Patients Previously Enrolled in NIH **Gene Therapy** Studies

EMA gene therapy approvals

EMA approval year	Product name		Condition	delivery
	<u>Ex vivo</u>			
2016	Strimvelis	CD34+ retrov	ADA-SCID	i.v.
2018	Kymriah	CAR-T	lymphoma	i.v.
2018	Yescarta	CAR-T	lymphoma	i.v.
2020	Libmeldy	CD34+ lentiv	arylsulfatase A- metachromatic leukodystrophy	i.v.
(2020) withdrawn	Zynteglo	CD34+ lentiv	B-thal	i.v.
2020	Tecartus	CAR-T	leukemia	i.v.
2021	Abecma	CAR-T	myeloma	i.v.
(2021) withdrawn	Skysona	CD34+ lentiv	ABCD1 - adrenoleukodystrophy	i.v.
2022	Carvykti	CAR-T	myeloma	i.v.
2022	Breyanzi	CAR-T	lymphoma	i.v.
	<u>In vivo</u>			
(2012) withdrawn	Glybera	LPL-AAV1	lipoprotein lipase deficiency	i.m.
2015	Imlygic	oncolytic HSV- GM-CSF	melanoma	intratumor
2018	Luxturna	RPE65-AAV2	Leber's congenital amaurosis	i.o.
2020	Zolgensma	SMN1-lenti	SMA	i.v.
2022	Roctavian	FVIII-AAV5	Haemophilia A	i.v.
2022	Upstaza	AADC- AAV2	aromatic L-amino acid decarboxylase deficiency	intracerebral
2023	Hemgenix	FIX-AAV	Haemophila B	i.v.



ADA-SCID Adenosine deaminase deficiency

Jim de Leon, Courtesy of Texas Children's Hospital

'Bubble boy' David Vetter had severe combined immunodeficiency, which left him vulnerable to infection.

Gene Therapy for ADA-SCID

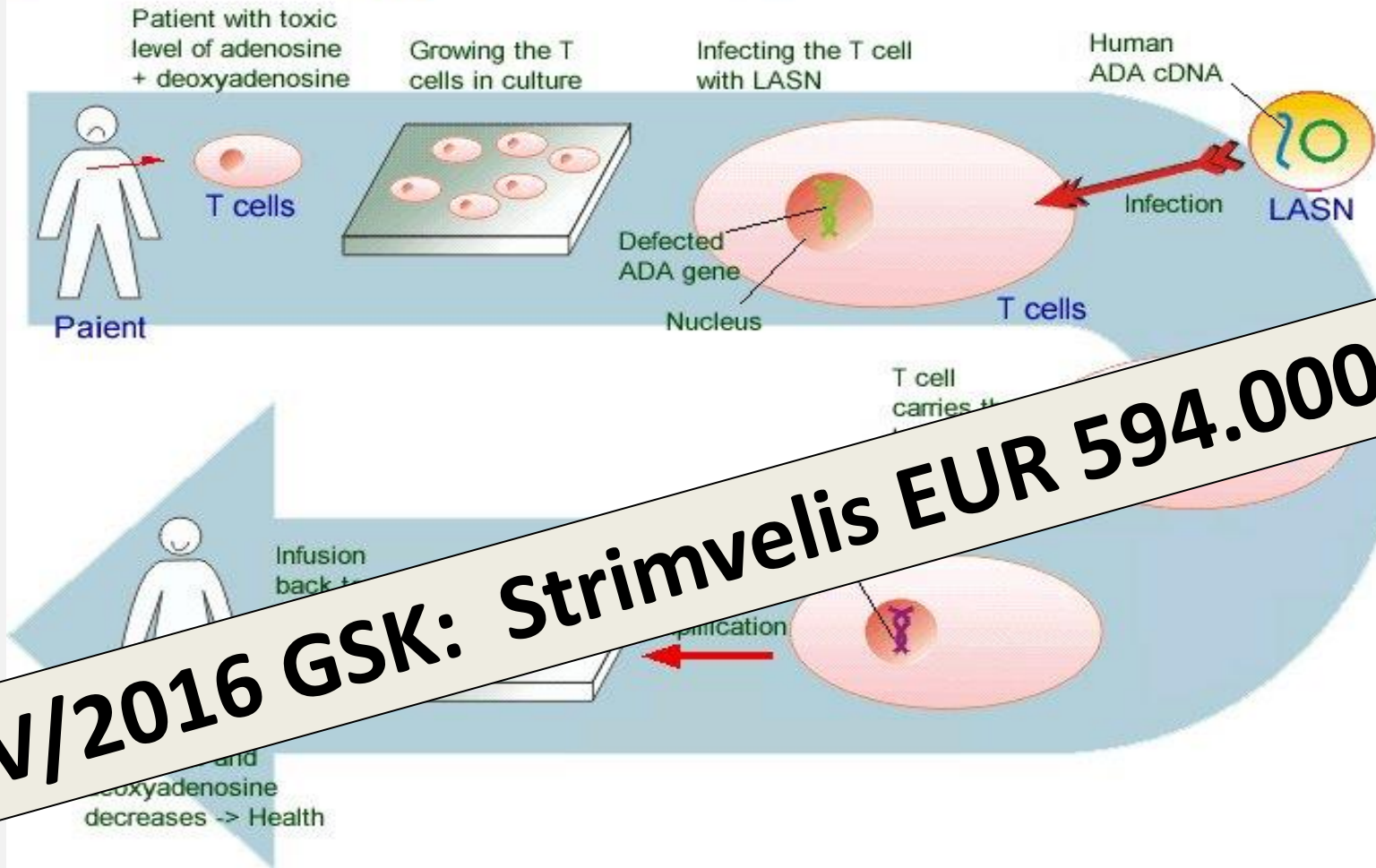

V/2016 GSK: Strimvelis EUR 594.000

Maria Pia Cicalese et al (2016)
Blood-2016-01-688226

- **18 patients**, donor not available, not responding to ERT.
- autologous CD34⁺ retrovirally transduced
- survival 100%
- 2.3 to 13.4 (median: 6.9) years. Severe infections from 1.17 to 0.17 events/py

“vanha” geeniterapia vs. geenimuokkaus



References Mailings Review View

Jamie Oliver's pizza

Jamie Oliver's

Ingredients

- 1 kg white bread flour or Tipo '00' flour
- bread flour or Tipo '00' flour, plus 20g flour
- 15½ teaspoon fine sea salt
- 2 x 7 g dried yeast sachets
- 1 tablespoon golden caster sugar
- 4 tablespoons extra virgin olive oil

Method

Sieve the flour/s and salt on to a clean surface, making a well in the middle.

In a jug, mix the yeast, sugar and oil with warm water and leave for a few minutes, then add the flour. Using a fork, bring the flour in gradually, then swirl it into the liquid. Keep mixing, drawing larger amounts of flour in, and when it all starts to come together, work the rest of the flour in with your clean, flour-dusted hands. Knead until you have a smooth, springy dough.

Place the ball of dough in a large flour-dusted bowl and flour the top of it. Cover the bowl with a damp cloth and place in a warm room for about an hour until the dough has doubled in size. Now remove the dough to a flour-dusted surface and knead it around a bit to push the air out with your hands – this is called knocking back the dough. You can either use it immediately, or



DNA:n muutos rekombinaatiolla

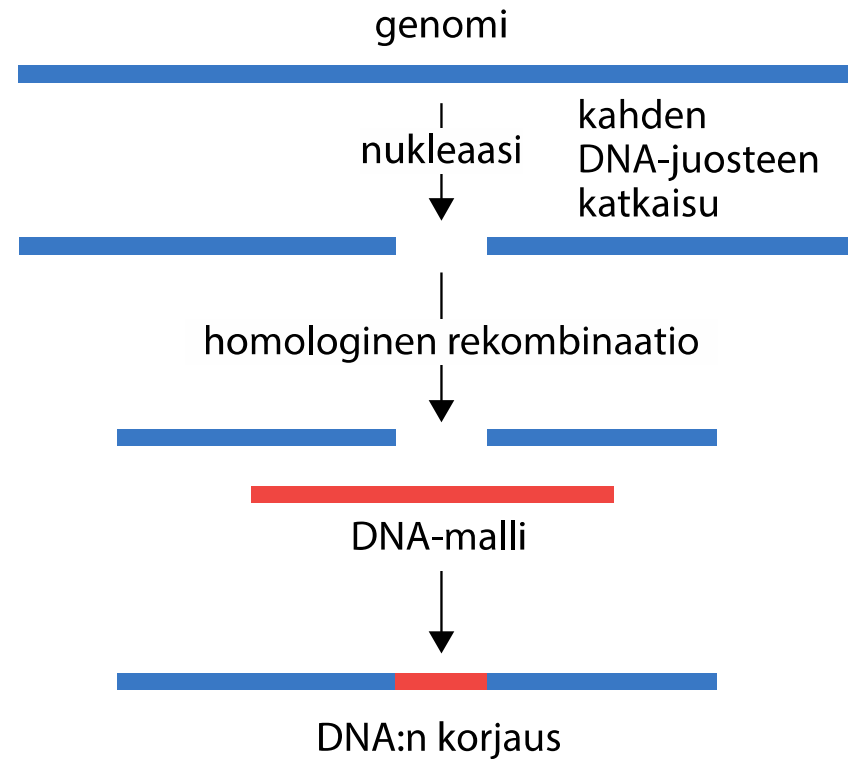

KUVA 10.1. Homologinen rekombinaatio.

Genome editing technologies

1. Hybrid meganuclease



2. Zinc-Finger Nuclease

ZFN



Zinc finger domains



3. Transcription Activator-like Effector Nuclease

TALEN



TALE subunits



active FokI catalytic subunit heterodimer



The NEW ENGLAND JOURNAL of MEDICINE

[HOME](#)[ARTICLES & MULTIMEDIA ▾](#)[ISSUES ▾](#)[SPECIALTIES & TOPICS ▾](#)[FOR AUTHORS ▾](#)[CME >](#)

ORIGINAL ARTICLE

Gene Editing of *CCR5* in Autologous CD4 T Cells of Persons Infected with HIV

Pablo Tebas, M.D., David Stein, M.D., Winson W. Tang, M.D., Ian Frank, M.D., Shelley Q. Wang, M.D., Gary Lee, Ph.D., S. Kaye Spratt, Ph.D., Richard T. Surosky, Ph.D., Martin A. Giedlin, Ph.D., Geoff Nichol, M.D., Michael C. Holmes, Ph.D., Philip D. Gregory, Ph.D., Dale G. Ando, M.D., Michael Kalos, Ph.D., Ronald G. Collman, M.D., Gwendolyn Binder-Scholl, Ph.D., Gabriela Plesa, M.D., Ph.D., Wei-Ting Hwang, Ph.D., Bruce L. Levine, Ph.D., and Carl H. June, M.D.

N Engl J Med 2014; 370:901-910 | [March 6, 2014](#) | DOI: 10.1056/NEJMoa1300662

The Nobel Prize in Chemistry 2020



© Nobel Media. Ill. Niklas Elmehed.

**Emmanuelle
Charpentier**

Prize share: 1/2



© Nobel Media. Ill. Niklas Elmehed.

Jennifer A. Doudna

Prize share: 1/2

The Nobel Prize in Chemistry 2020 was awarded jointly to Emmanuelle Charpentier and Jennifer A. Doudna "for the development of a method for genome editing."

Genome editing clinical trials VIII/2023

ZFNs	17
TALENs	9
CRISPRs	72 (of which 14 in diagnostics)

No market approvals for gene editing medicinal products

CRISPR = Clustered Regularly Interspaced Short Palindromic Repeats

NATURE REVIEWS | MICROBIOLOGY

Amitai & Sorek (2016)

a Locus organization



b Adaptation

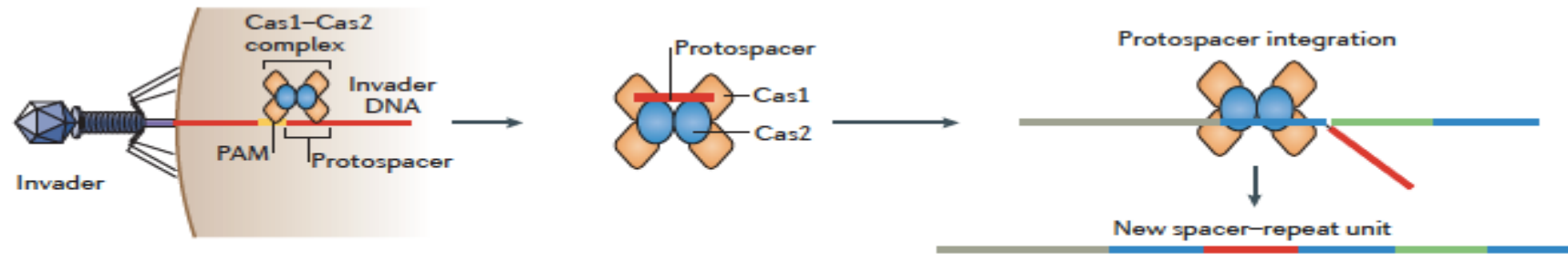

c Expression and maturation

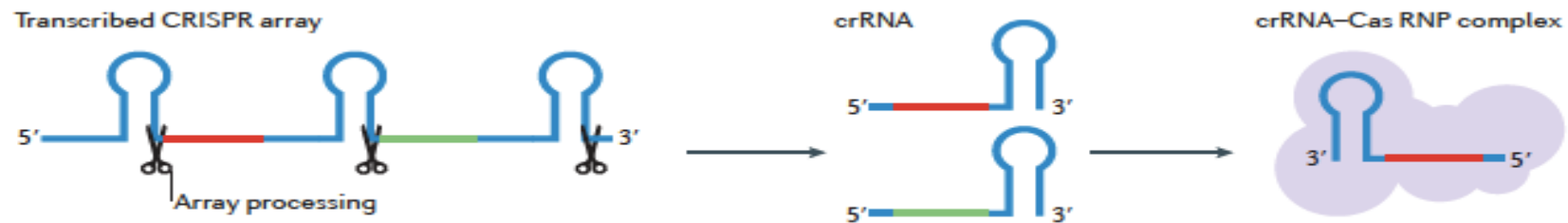

d Interference

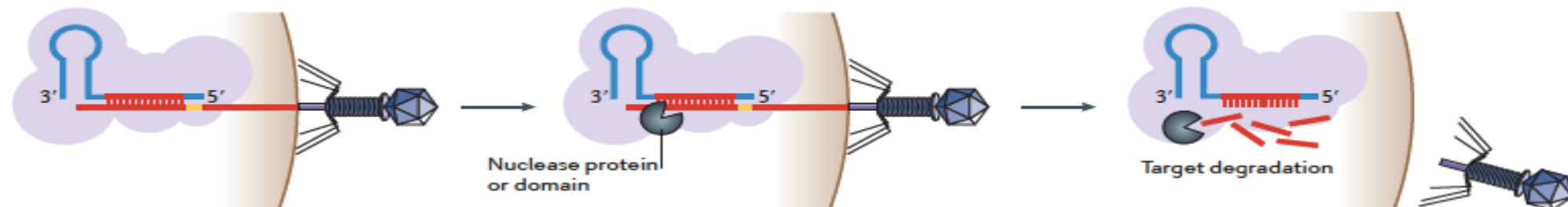

1. RNA-ohjain vie Cas9-entsyymin haluttuun kohtaan DNA:ssa
2. DNA avataan ja katkaistaan

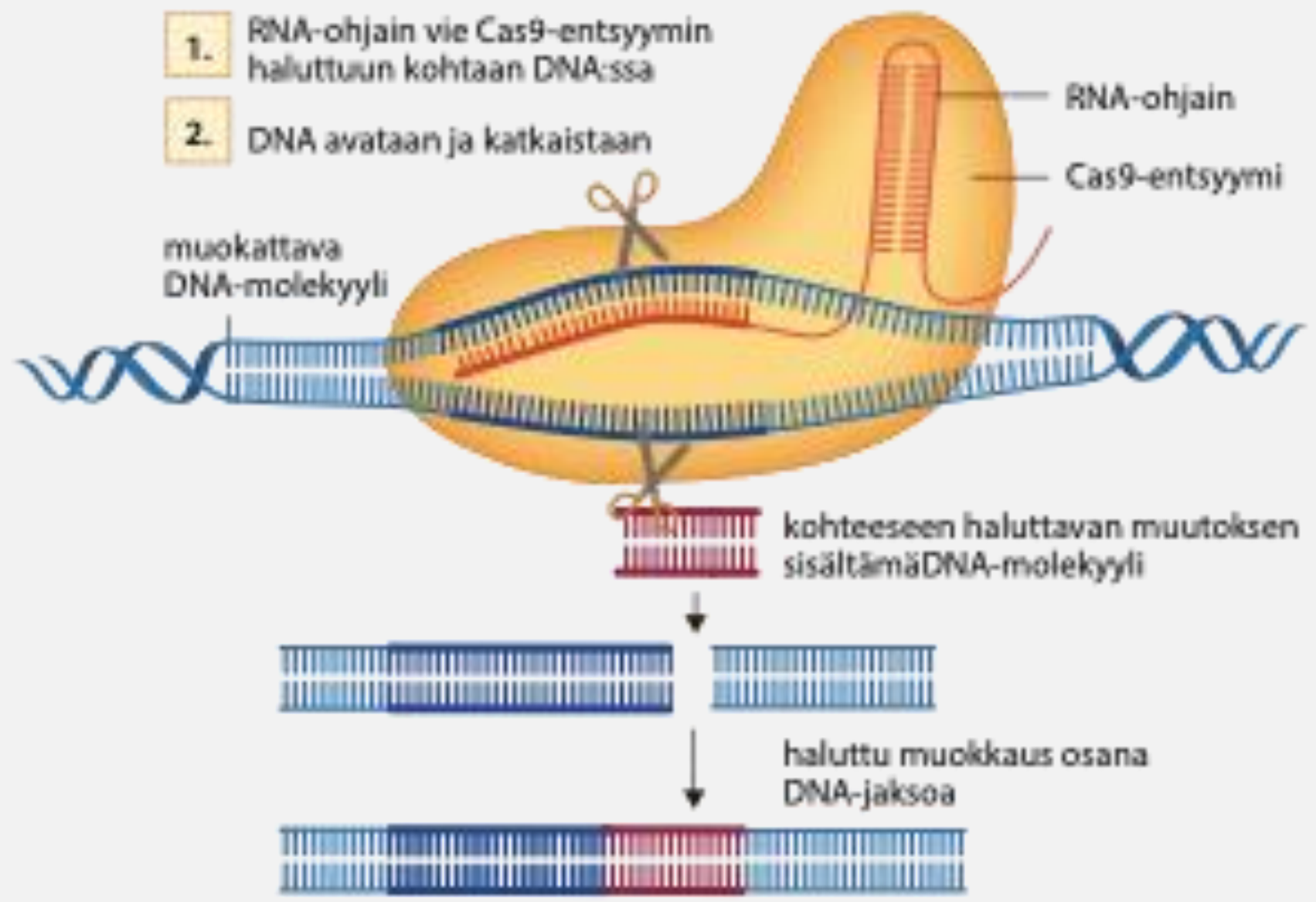

Tautimallinnus potilassoluilla

MUTAATIO



Patient-iPS HEL71.4
Heterozygous mutation

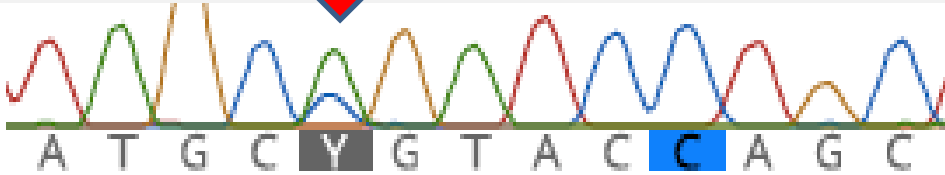

Corrected clone F2

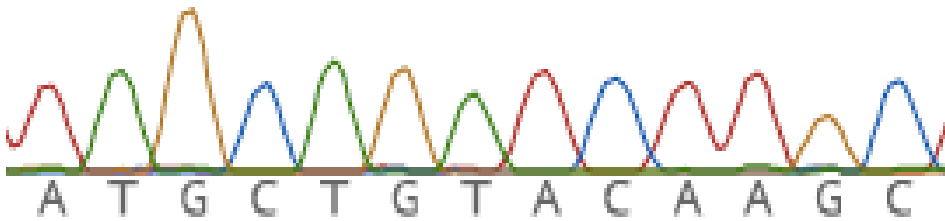

KORJATTU

Balboa et al. 2018

Ensimmäinen CRISPR-koe ihmisellä

NATURE | NEWS



CRISPR gene-editing tested in a person for the first time

The move by Chinese scientists could spark a biomedical duel between China and the United States.

David Cyranoski

15 November 2016



PDF



Rights & Permissions

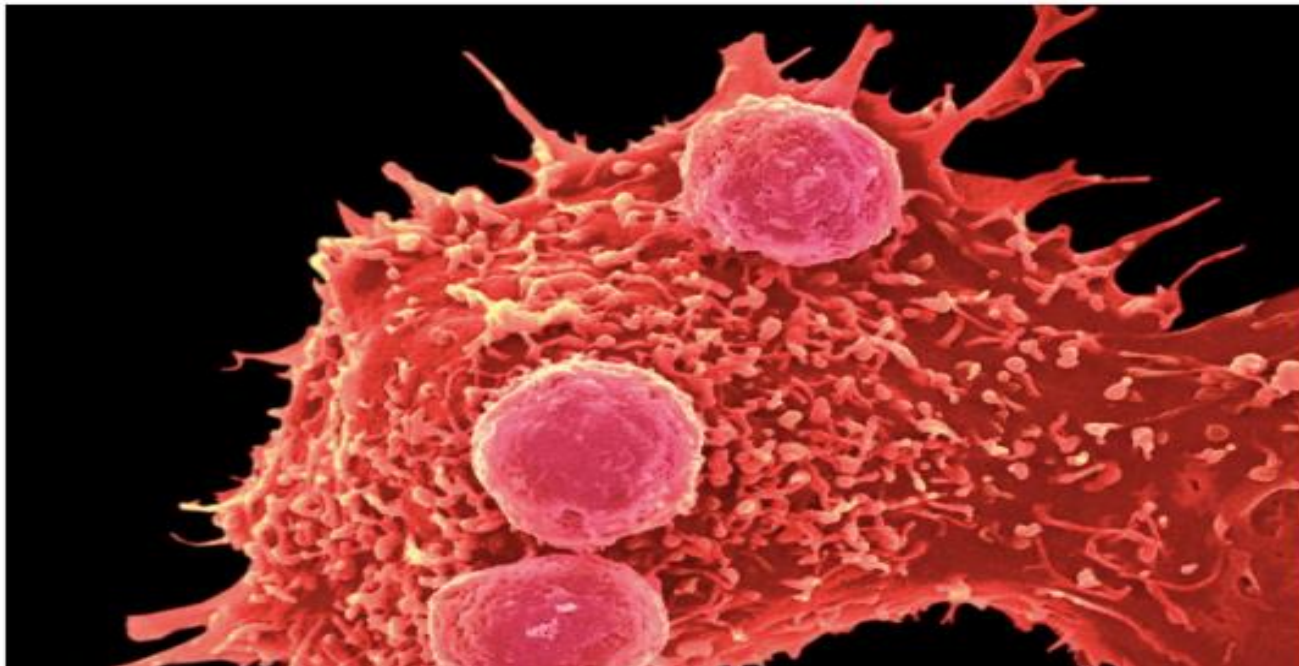

PD-1 poistogeeniset
immuunisolut injektoitu
potilaaseen, jolla pitkälle
edennyt keuhkosyöpä

CRISPRed cells appear to be safe

Stadtemauer EA, et al. *Science* 367:
(2020)

RESEARCH ARTICLE SUMMARY

CLINICAL TRIALS

CRISPR-engineered T cells in patients with refractory cancer

Edward A. Stadtmauer*†, Joseph A. Fraietta*, Megan M. Davis, Adam D. Cohen, Kristy L. Weber, Eric Lancaster, Patricia A. Mangan, Irina Kulikovskaya, Minnal Gupta, Fang Chen, Lifeng Tian, Vanessa E. Gonzalez, Jun Xu, In-young Jung, J. Joseph Melenhorst, Gabriela Plesa, Joanne Shea, Tina Matlawski, Amanda Cervini, Avery L. Gaymon, Stephanie Desjardins, Anne Lamontagne, January Salas-McKee, Andrew Fesnak, Donald L. Siegel, Bruce L. Levine, Julie K. Jadlofsky, Regina M. Young, Anne Chew, Wei-Ting Hwang, Elizabeth O. Hexner, Beatriz M. Carreno, Christopher L. Nobles, Frederic D. Bushman, Kevin R. Parker, Yanyan Qi, Ansuman T. Satpathy, Howard Y. Chang, Yangbing Zhao, Simon F. Lacey*, Carl H. June*†

INTRODUCTION: Most cancers are recognized and attacked by the immune system but can progress owing to tumor-mediated immunosuppression and immune evasion mechanisms. The infusion of ex vivo engineered T cells, termed adoptive T cell therapy, can increase the natural antitumor immune response of the patient. Gene therapy to redirect immune specificity combined with genome editing has the potential to improve the efficacy and increase the safety of engineered T cells. CRISPR coupled with CRISPR-associated protein 9 (Cas9) endonuclease is a powerful gene-editing technology that potentially allows the ability to target multiple genes in T cells to improve cancer immunotherapy.

RATIONALE: Our first-in-human, phase 1 clinical trial (clinicaltrials.gov; trial NCT03399448) was designed to test the safety and feasibility of multiplex CRISPR-Cas9 gene editing of T cells from patients with advanced, refractory cancer. A limitation of adoptively transferred T cell efficacy has been the induction of T cell dysfunction or exhaustion. We hypothesized that removing the endogenous T cell receptor (TCR) and the immune checkpoint molecule programmed cell death protein 1 (PD-1) would improve the function and persistence of engineered T cells. In addition, the removal of PD-1 has the potential to improve safety and reduce toxicity that can be caused by autoimmunity.

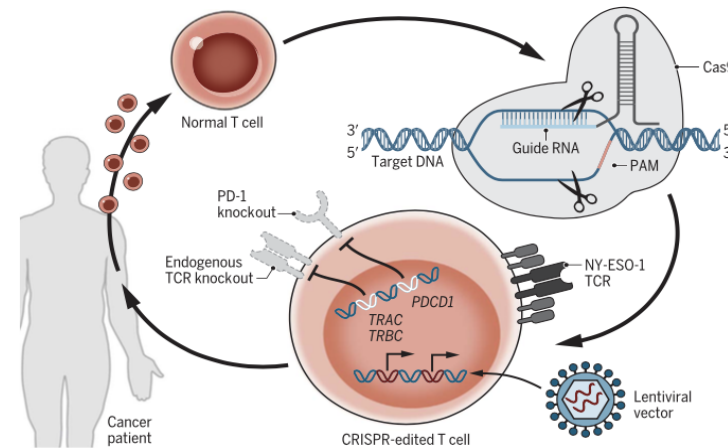

CRISPR-Cas9 engineering of T cells in cancer patients. T cells (center) were isolated from the blood of a patient with cancer. CRISPR-Cas9 ribonucleoprotein complexes loaded with three sgRNAs were electroporated into the normal T cells, resulting in gene editing of the *TRAC*, *TRBC1*, *TRBC2*, and *PDCDI* (encoding PD-1) loci. The cells were then transduced with a lentiviral vector to express a TCR specific for the cancer-testis antigens NY-ESO-1 and LAGE-1 (right). The engineered T cells were then returned to the patient by intravenous infusion, and patients were monitored to determine safety and feasibility. PAM, protospacer adjacent motif.

A synthetic, cancer-specific TCR transgene (NY-ESO-1) was also introduced to recognize tumor cells. In vivo tracking and persistence of the engineered T cells were monitored to determine if the cells could persist after CRISPR-Cas9 modifications.

RESULTS: Four cell products were manufactured at clinical scale, and three patients (two with advanced refractory myeloma and one with metastatic sarcoma) were infused. The editing efficiency was consistent in all four products and varied as a function of the single guide RNA (sgRNA), with highest efficiency observed for the TCR α chain gene (*TRAC*) and lowest efficiency for the TCR β chain gene (*TRBC*). The mutations induced by CRISPR-Cas9 were highly specific for the targeted loci; however,

ON OUR WEBSITE

Read the full article at <http://dx.doi.org/10.1126/science.aba7365>

rare off-target edits were observed. Single-cell RNA sequencing of the infused CRISPR-engineered T cells revealed that ~30% of cells had no detectable mutations, whereas ~40% had a single mutation and ~20 and ~10% of the engineered T cells were double mutated and triple mutated, respectively, at the target sequences. The edited T cells engrafted in all three patients at stable levels for at least 9 months. The persistence of the T cells expressing the engineered TCR was much more durable than in three previous clinical trials during which T cells were infused that retained expression of the endogenous TCR and endogenous PD-1. There were no clinical toxicities associated with the engineered T cells. Chromosomal translocations were observed in vitro during cell manufacturing, and these decreased over time after infusion into patients. Biopsies of bone marrow and tumor showed trafficking of T cells to the sites of tumor in all three patients. Although tumor biopsies revealed residual tumor, in both patients with myeloma, there was a reduction in the target antigens NY-ESO-1 and/or LAGE-1. This result is consistent with an on-target effect of the engineered T cells, resulting in tumor evasion.

CONCLUSION: Preliminary results from this pilot trial demonstrate that multiplex human genome engineering is safe and feasible using CRISPR-Cas9. The extended persistence of the engineered T cells indicates that preexisting immune responses to Cas9 do not appear to present a barrier to the implementation of this promising technology. ■

The list of author affiliations is available in the full article online.
*These authors contributed equally to this work.
†Corresponding author. Email: edward.stadtemauer@penmedicine.upenn.edu (E.A.S.); cjune@upenn.edu (C.H.J.)
Cite this article as E. A. Stadtmauer et al., *Science* 367, eaba7365 (2020). DOI: 10.1126/science.aba7365



<https://www.sciencehistory.org>

How safe is safe enough?

DISTILLATIONS

USING STORIES FROM SCIENCE'S PAST TO UNDERSTAND OUR WORLD

PANDEMIC PERSPECTIVES

CULTURE

EARLY SCIENCE & ALCHEMY

ENVIRONMENT

HEALTH

PEOPLE

POLICY & POLITICS

TOOLS & TECHNOLOGY

PODCAST

VIDEO

ABOUT

SUBSCRIBE

Share

HEALTH

The Death of Jesse Gelsinger, 20 Years Later

Gene editing promises to revolutionize medicine. But how safe is safe enough for the patients testing these therapies?

By [Meir Rinde](#) | June 4, 2019



Photo illustration by Clay Cansler

Avoimia kysymyksiä geenimuokkauksessa:

1. Tekniikat

- Tarkkuus, riskit => biologinen turvallisuus:
(väärät kohteet, korjausmekanismit,
pitkäaikaisvaikutukset)
- Parhaat menetelmät => tehokkuus, bioturva:
viejävektorit, laitteet, kohdesolujen erilaisuudet

Avoimia kysymyksiä geenimuokkauksessa:

2. Yhteiskunta

- Tekijät ja osaaminen, koulutus
- Viranomaisten vaatimukset (kaupalliset intressit)
- Julkinen mielipide ja etiikka
 - Hinta, globaali tasa-arvo
 - Tautien hoito vs. henkilökohtaiset parannukset
 - Periytyvät muutokset
 - Muut lajit

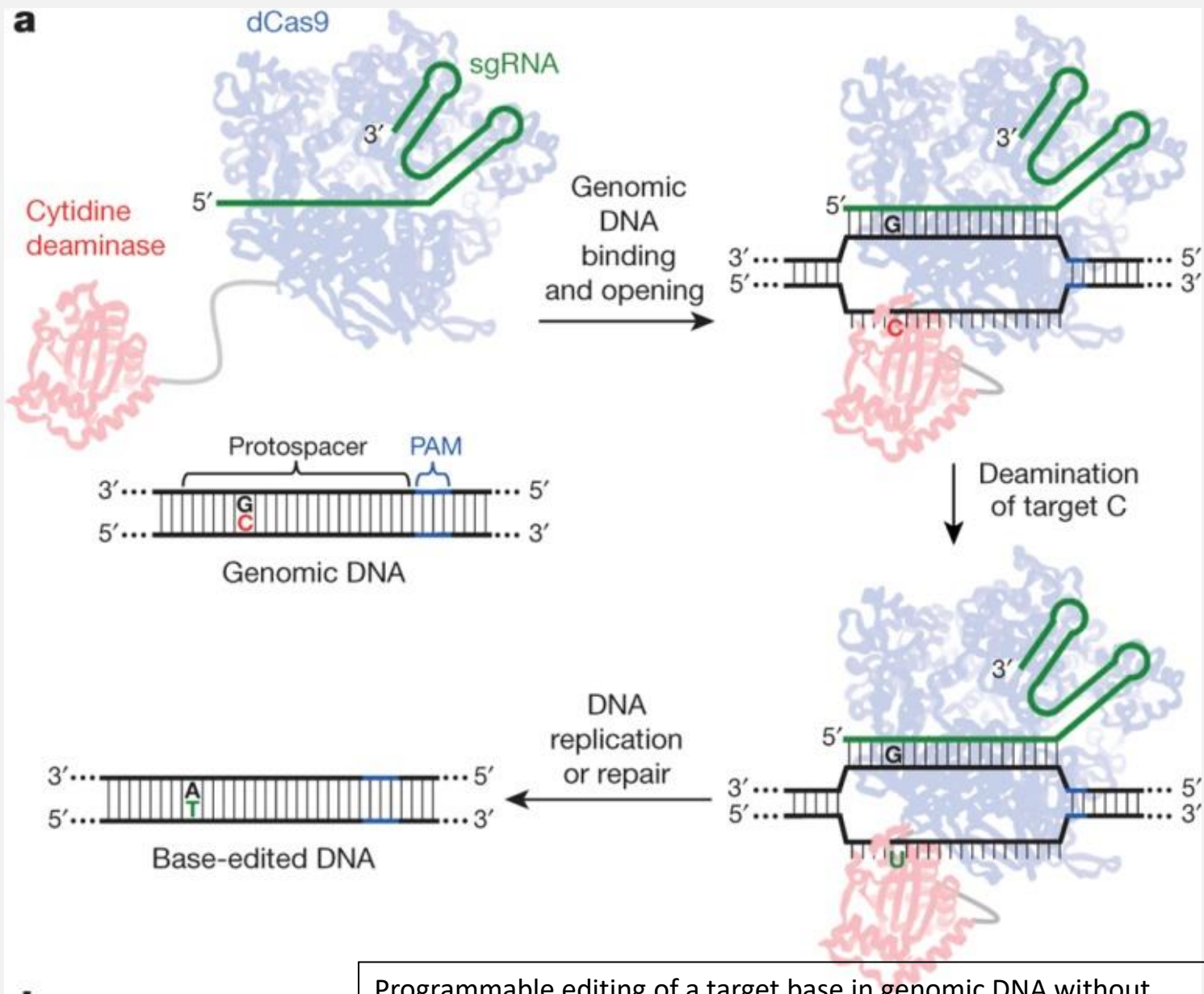

Programmable editing of a target base in genomic DNA without double-stranded DNA cleavage
 A C Komor *et al. Nature* **533**, 420–424 (2016)

Hemophilia A (F8 gene) mutation correction

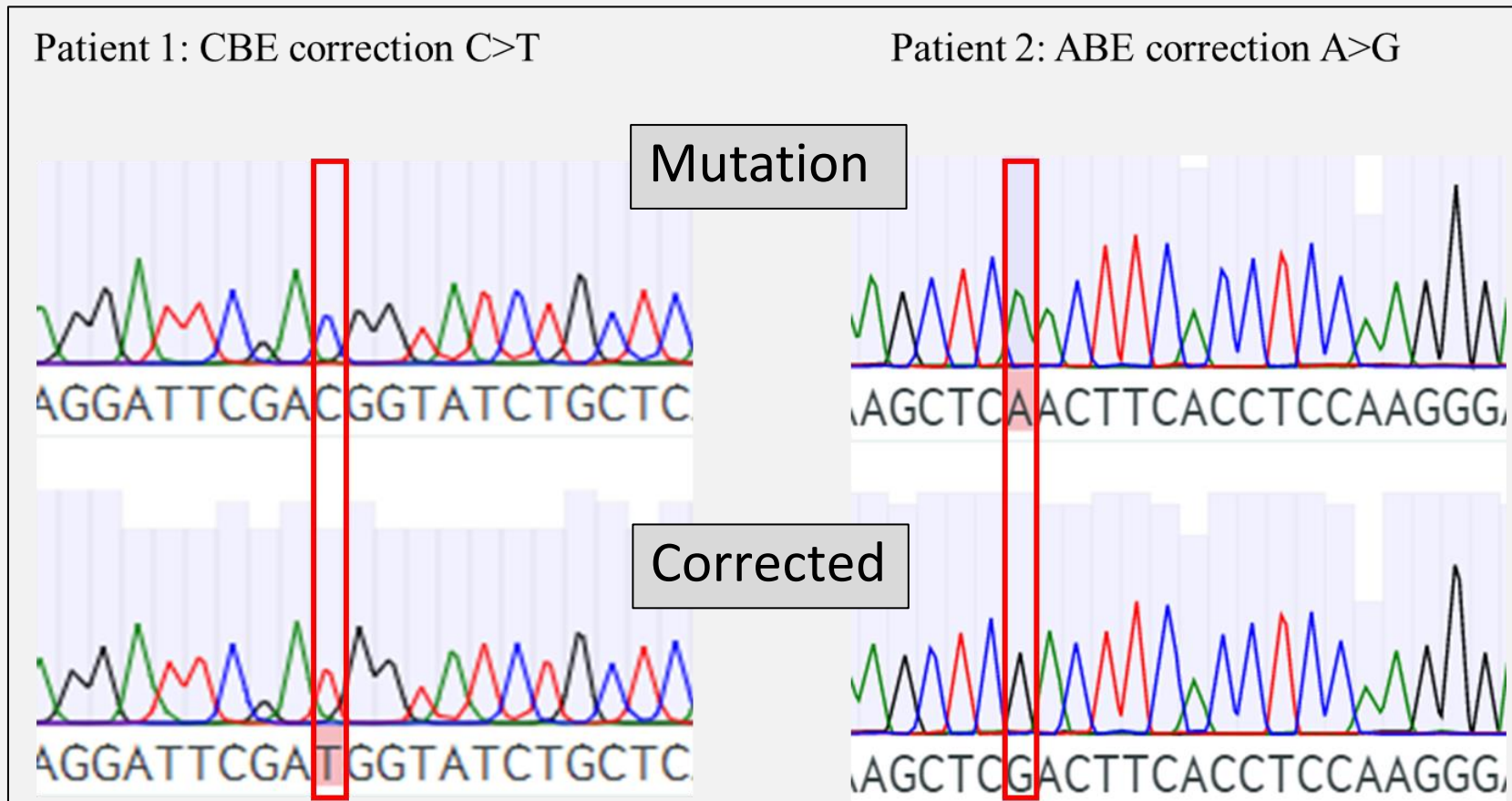

Soppa et al,
unpublished

Alkion geenimuokkaus

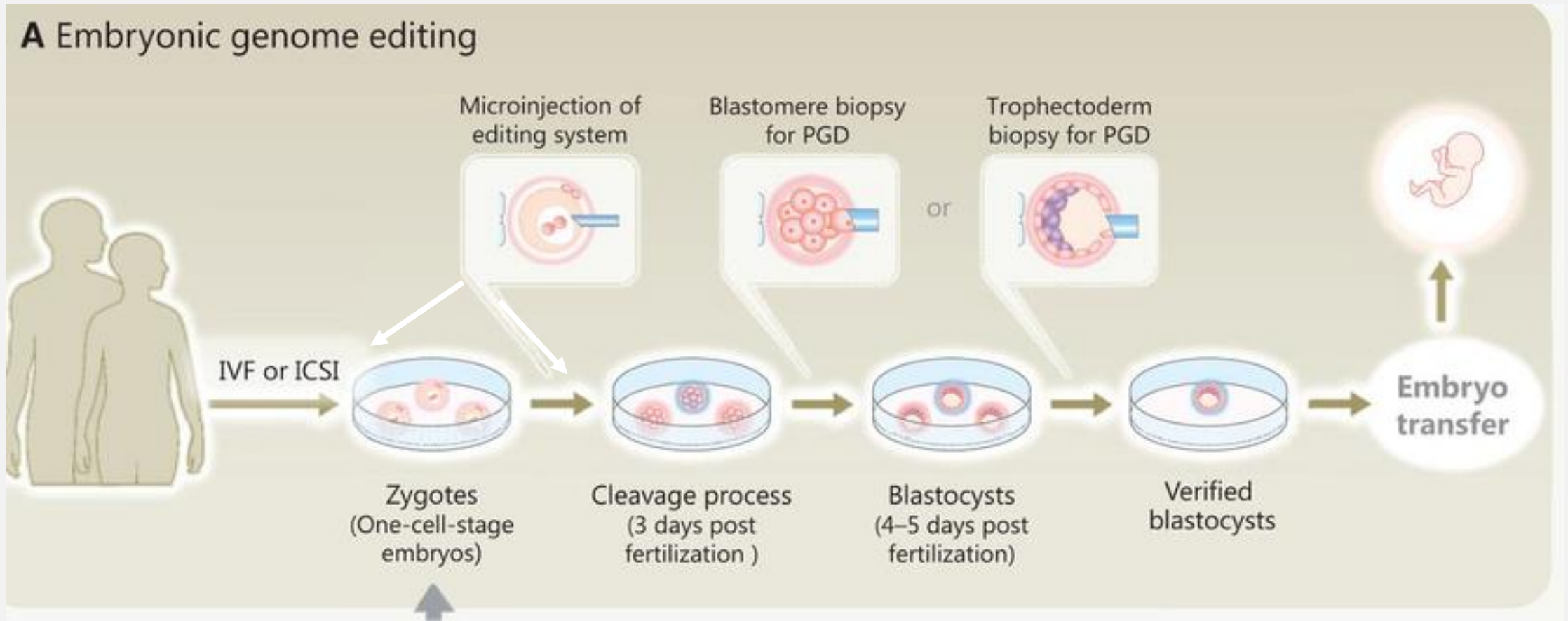



Correction of a pathogenic gene mutation in human embryos

[Hong Ma](#), [Nuria Marti-Gutierrez](#), [Sang-Wook Park](#), [Jun Wu](#), [Yeonmi Lee](#), [Keiichiro Suzuki](#), [Amy Koski](#), [Dongmei Ji](#), [Tomonari Hayama](#), [Riffat Ahmed](#), [Hayley Darby](#), [Crystal Van Dyken](#), [Ying Li](#), [Eunju Kang](#), [A.-Reum Park](#), [Daesik Kim](#), [Sang-Tae Kim](#), [Jianhui Gong](#), [Ying Gu](#), [Xun Xu](#), [David Battaglia](#), [Sacha A. Krieg](#), [David M. Lee](#), [Diana H. Wu](#), [Don P. Wolf](#), [Stephen B. Heitner](#), [Juan Carlos Izpisua Belmonte](#), [Paula Amato](#), [Jin-Soo Kim](#), [Sanjiv Kaul](#) & [Shoukhrat Mitalipov](#)

 [Show fewer authors](#)

[Affiliations](#) | [Contributions](#) | [Corresponding authors](#)

Nature (2017) | doi:10.1038/nature23305

Received 28 March 2017 | Accepted 27 June 2017 | Published online 02 August 2017



European Academies



Science Advisory Council

**Genome editing: scientific opportunities,
public interests and policy options in the
European Union**



Heritable Human Genome Editing

International Commission on the
Clinical Use of Human Germline Genome Editing

A Consensus Study Report of the
NATIONAL ACADEMY OF MEDICINE AND
NATIONAL ACADEMY OF SCIENCES

and

THE
ROYAL
SOCIETY

THE NATIONAL ACADEMIES PRESS
Washington, DC
www.nap.edu

He Jiankui: "Ensimmäiset geenimuokatut lapset ovat syntyneet"



Ihmiskunnan DNA –elämän koodin kirjoitus

1. Biologian/lääketieteen kysymys: mitä DNA:ssa lukee? *Mitkä muutokset ovat hyviä ihmiselle/muille eliöille/maapallolle?*
2. (Bio)tekninen kysymys: miten DNA:ta muokataan? *Parhaat tekniikat? Uudet osaamisalueet, kuten epigenetiikka?*
3. Yhteiskunnallinen kysymys: miten DNA:n lukeminen tai muokkaus voi vaikuttaa ihmisiin? *Mitä saa tehdä? Kuka päättää?*

Kirjan esimerkkejä:

- DNA-tekniikan syntyminen
- Kultainen Riisi
- biohakkerointi
- itsestään leviävät rokotteet
- potilastapauksia

Mäntyrintan geenit ja doping

Eero Mäntyranta (1937-2013) oli yksi kaikkien aikojen menestyneimmistä suomalaista hiihtäjistä, neljän olympiakisojen urheilija, joista hän sai kotiintuomisiksi seitsemän mitalia. Mäntyrintan parhaat vuodet osuivat 1964 Innsbruckin olympialaisiin, joissa hän voitti selvällä erolla muihin kaksi henkilökohtaista kultamitalia ja viestihopeaa.

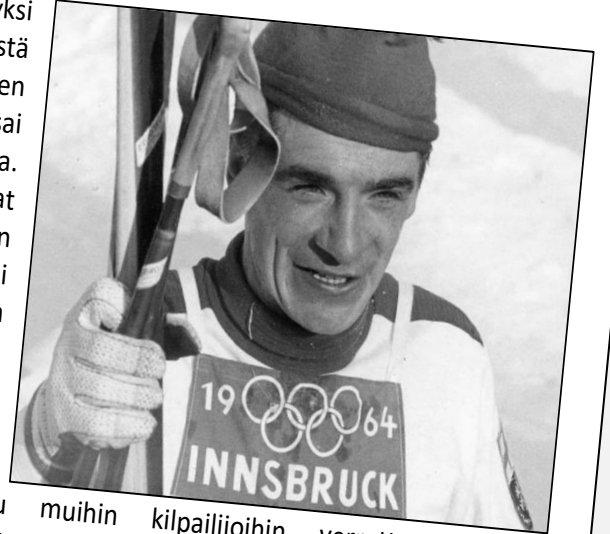

Mäntyranta oli lähtöisin vaatimattomista oloista ja kova harjoittelija, mutta hänellä oli myös syntymälahjana saatu etu muihin kilpailijoihin verrattuna: hänen hemoglobiiniarvonsa oli yli 200 grammaa/litra. Miesten tavallinen Hb-lukema on alle 170, ja koska hemoglobiinin tehtävä on kuljettaa happea, Mäntyrintan veri oli erityisen sopivaa kovan hapenkulutuksen kestävyysurheiluun. Suurin häneltä mitattu arvo on tietävästi yli 230, joka on jo hyvin merkittävä veritulpan riskitekijä.

Mäntyrintan hemoglobiinin korkean arvon syy selvisi vasta lähes 30 vuotta hänen parhaiden saavutustensa jälkeen, kun suomalaiset geenitutkijat kuvasivat löytämänsä geenivirheen hänen soluistaan. Mäntyrintanalla ja monilla hänen sukulaisellaan oli muutos erytropoietiinireseptori eli EPOR-geenissä, minkä vuoksi keho ei osaa sulkea EPO-hormonin tuotantoa ja tekee liian paljon punasoluja. Tilaa kutsutaan primaariksi polysytemiaksi. Synnynnäisen syyn löytyminen teki lopun myös puheista, joiden mukaan Mäntyranta olisi käyttänyt hemoglobiinia nostavia lääkkeitä tai saanut verensiirtoja parantaakseen suorituksiaan.

DNA yksilöntunnistuksessa

Golden State killer

Kalifornian osavaltiossa tapahtui vuosina 1973–1986 ainakin 13 samankaltaista murhaa ja 50 raiskausta, joiden tekijää ei saatu kiinni. Tapausten tutkimuksessa löytyneiden DNA-näytteiden perusteella tiedettiin, että kyseessä oli sama tekijä, mutta millään ei saatu selville, kuka oli kyseessä. Viranomaiset eivät löytäneet omista tietokannoistaan tekijäksi tai hänen lähisukulaisekseen sopivan henkilön DNA-profiilia, ja vähitellen juttu kuivui kokoon. Tekijänkin arveltiin mahdollisesti jo kuolleen tai muuttaneen muualle.

Cro-Magnonin luola, Les Eysiez, Ranska



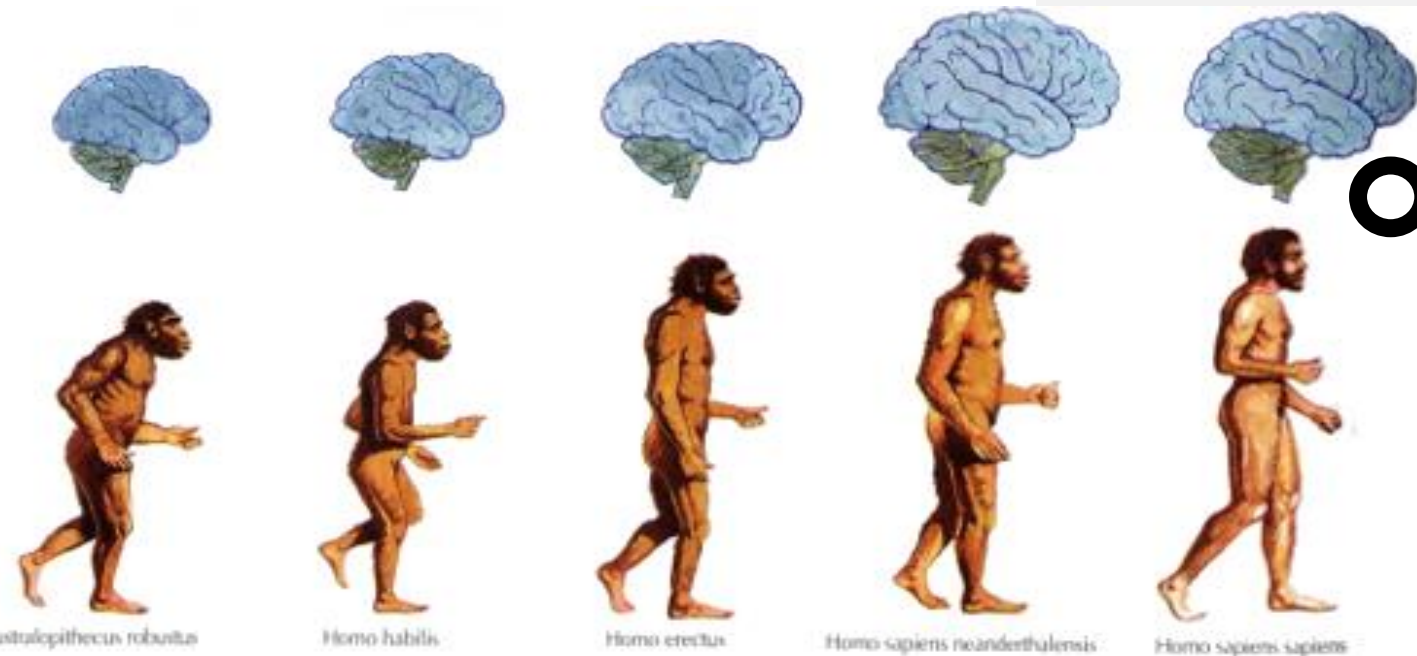
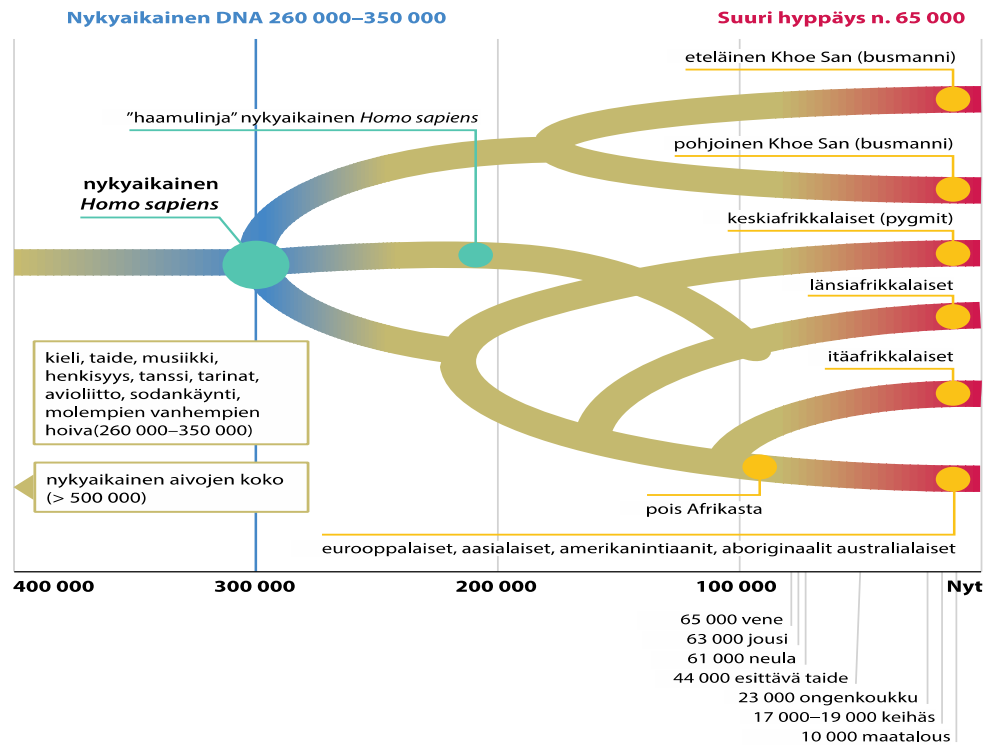

Evoluutio on johtanut kykyyn muokata evoluutiota.

Uusien tekniikoden ongelmia

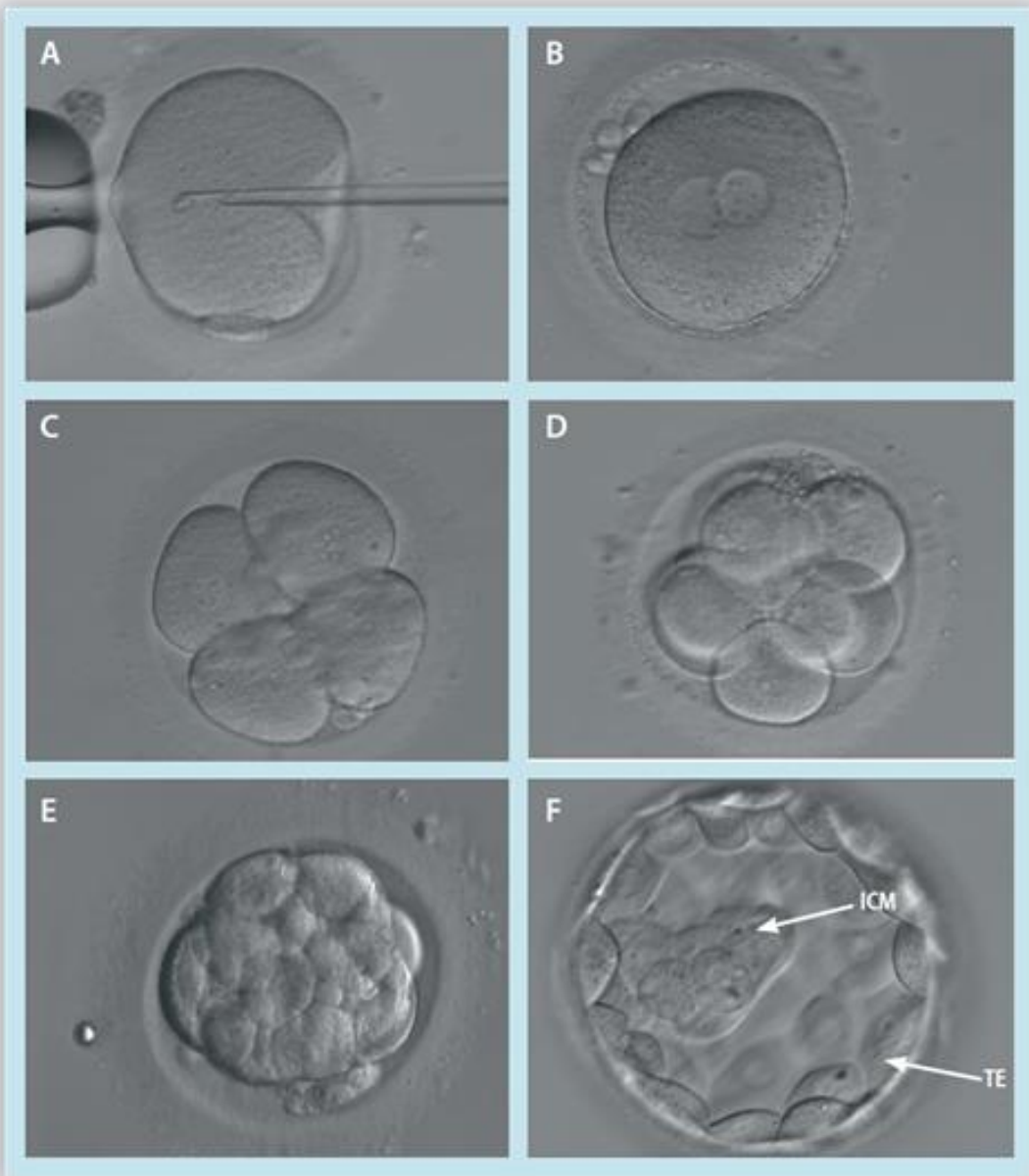

Yleiset:

Virhelähteet ja tietämisen varmuus

Riskienhallinta

Hyöty/haittasuhteiden arvioiminen

DNA:

Seulonnat, diagnostiikka, ennustavat testit,
tietosuoja-asiat, sukulaiset

Kotitestit

Sikiö/alkiotutkimukset

Dudecim 2018;134(22):2189-96

Hydén-Granskog, Anttonen, Tiitinen

CRISPR mahdollisuuksia

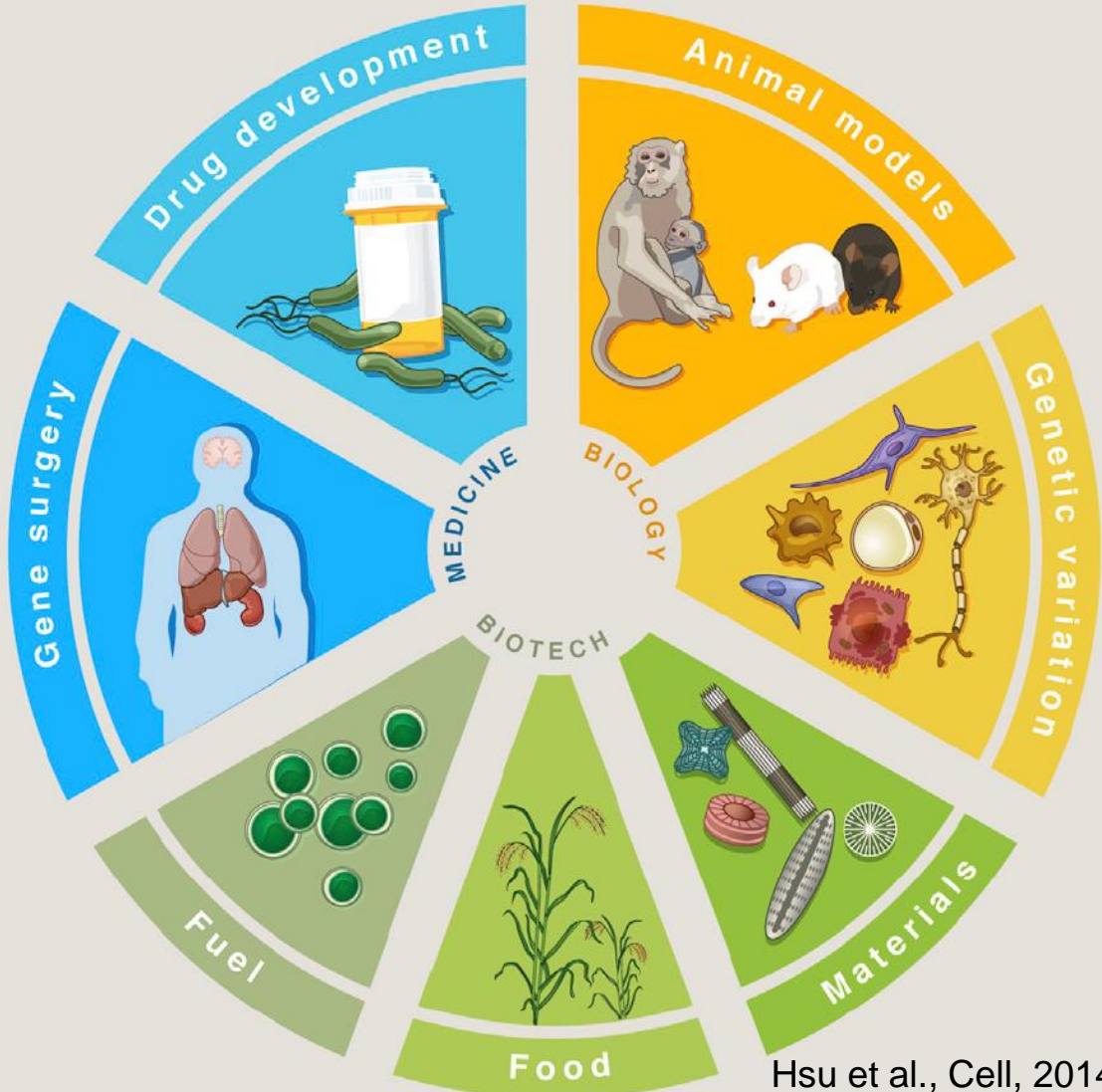

Hsu et al., Cell, 2014

nature International weekly journal of science

Home | News & Comment | Research | Careers & Jobs | Current Issue | Archive | Audio & Video

Archive > Volume 531 > Issue 7593 > News Feature > Article

NATURE | NEWS FEATURE

Welcome to the CRISPR zoo

Birds and bees are just the beginning for a burgeoning technology.

Sara Reardon

09 March 2016

The illustration depicts a circular zoo enclosure with a white roof. In the center is a large yellow circle containing a blue and red DNA double helix. Surrounding this central circle are several smaller circular enclosures, each containing a different animal: a brown mammoth in a snowy landscape, a blue bee, a pink pig, a brown cow, a yellow bird, and a black and white bee. A scientist in a white lab coat is standing on the right side of the enclosure, holding a yellow ball.

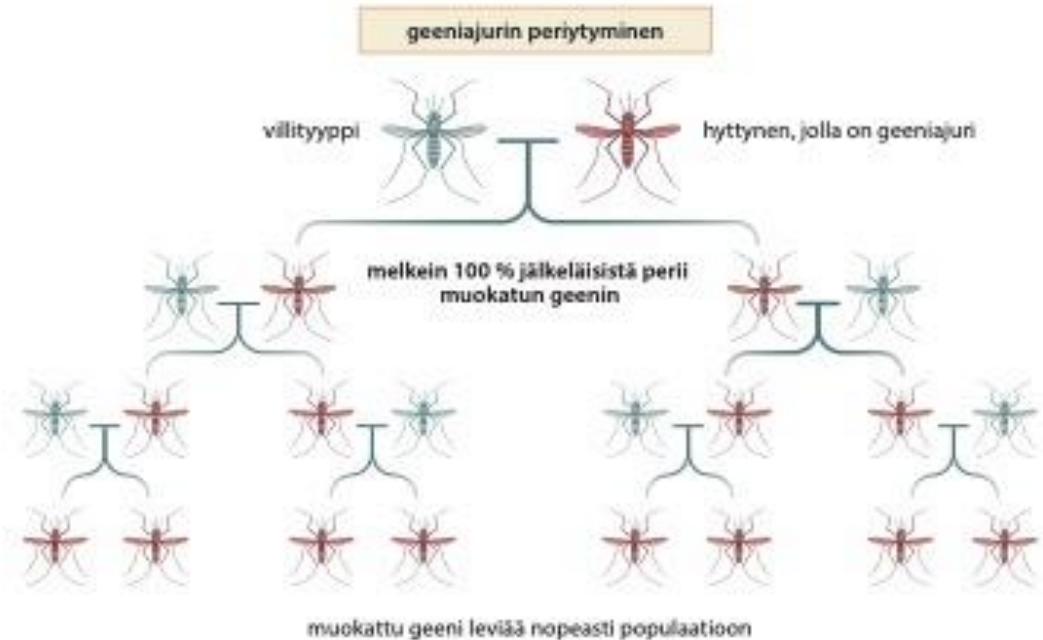
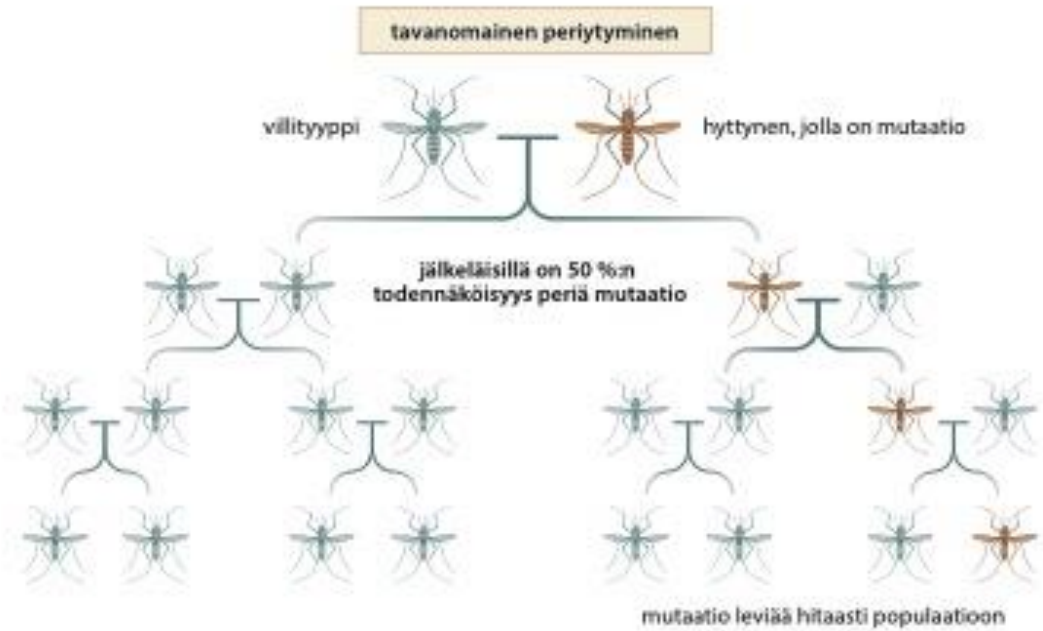

Geeniajuri periytyy lähes 100% jälkeläisille ja leviää nopeasti

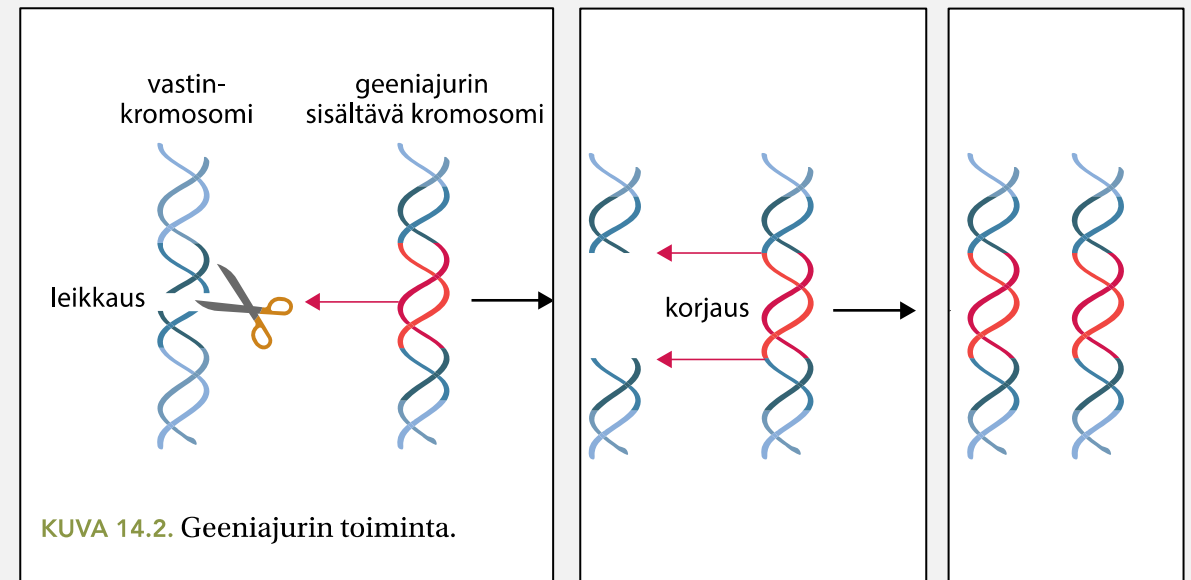

REPORT

Complete biosynthesis of opioids in yeast

Stephanie Galanie¹, Kate Thodey², Isis J. Trenchard², Maria Filsinger Interrante², Christina D. Smolke^{2,*}

+ See all authors and affiliations

Science 04 Sep 2015:
Vol. 349, Issue 6252, pp. 1095-1100
DOI: 10.1126/science.aac9373

- Synthetic biologists engineered 21 genes in total, including many added from a diverse set of species (see graphic); making hydrocodone took 23 genes.

New opiate factory

To engineer yeast to make opiates, researchers outfitted the microbes' chromosomes with genes from a rat (blue), a bacterium (orange), and several plants (green), including three forms of poppies.

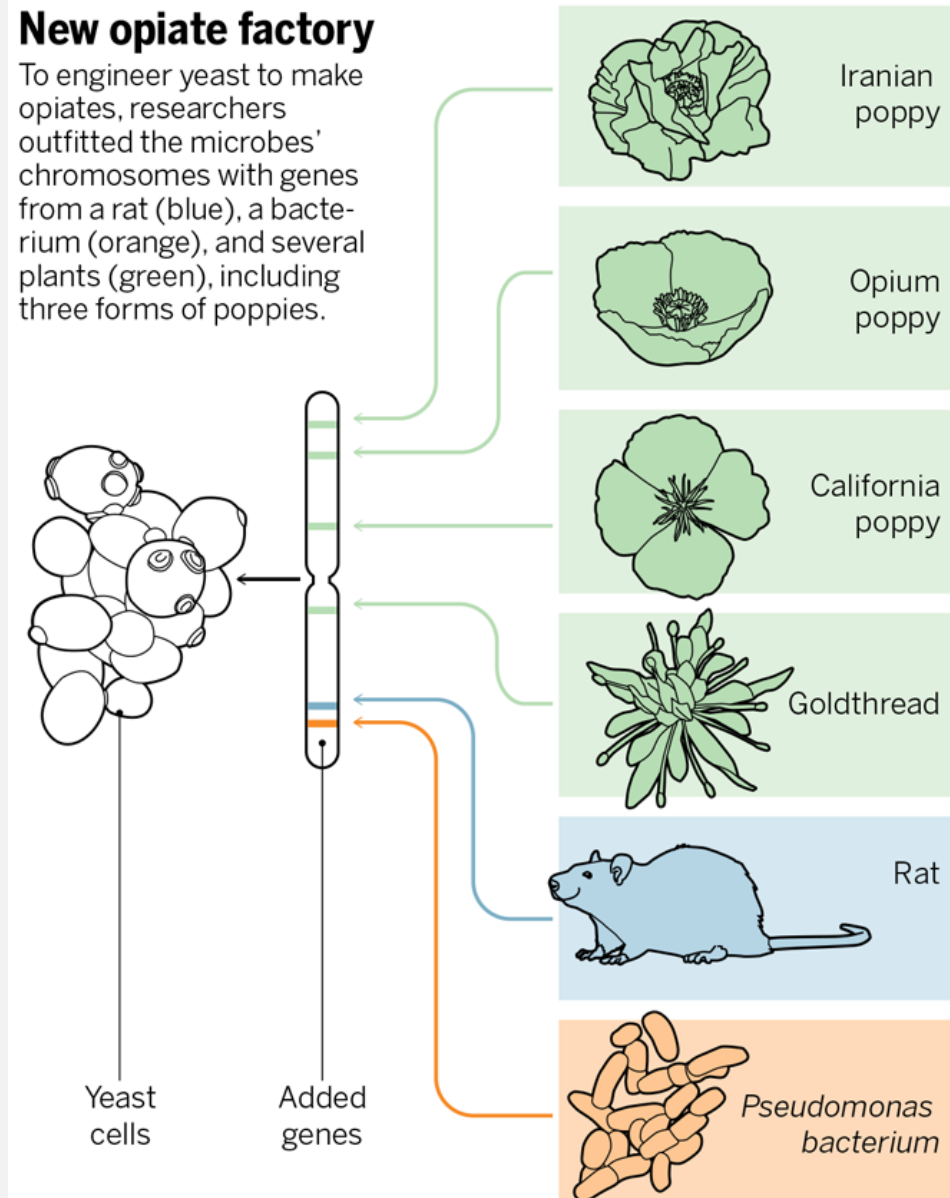

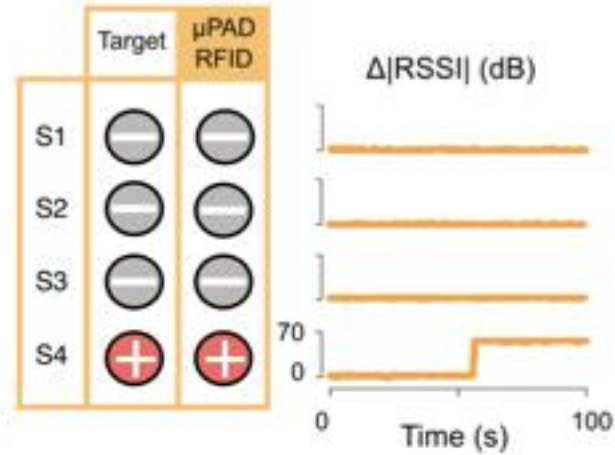
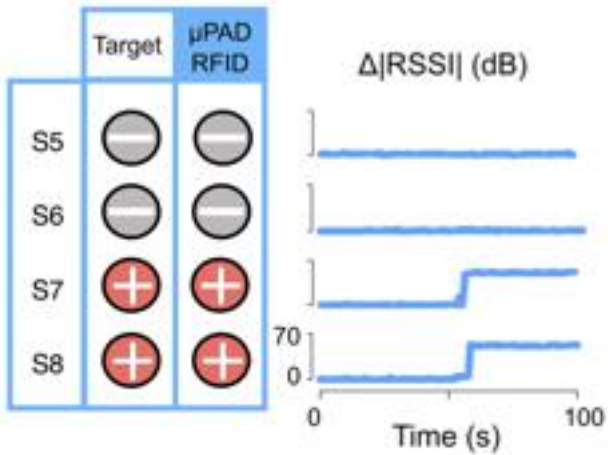
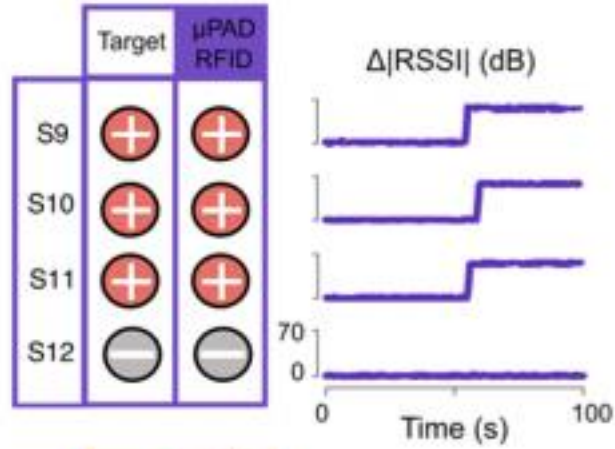

CRISPR hydrogel for ssRNA detection

English et al (2019). Programmable CRISPR-responsive smart materials
Science Vol. 365, Issue 6455, pp. 780-785

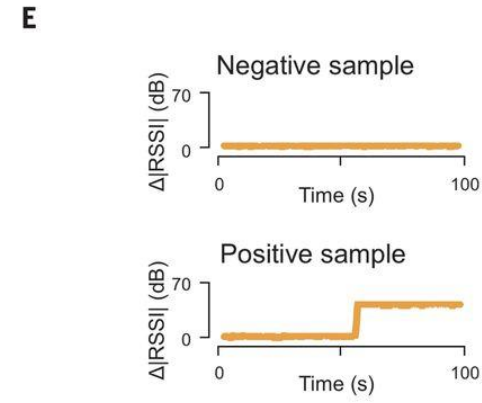
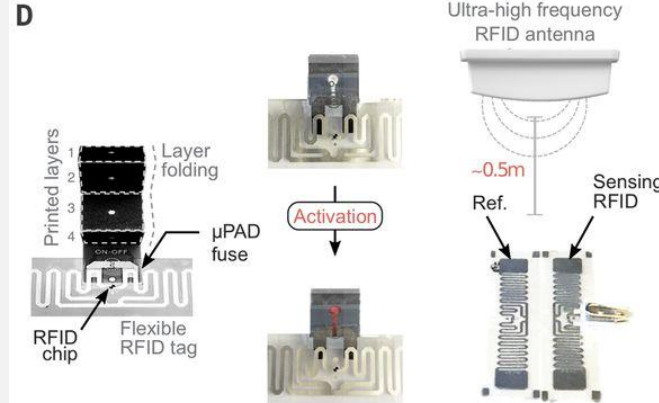
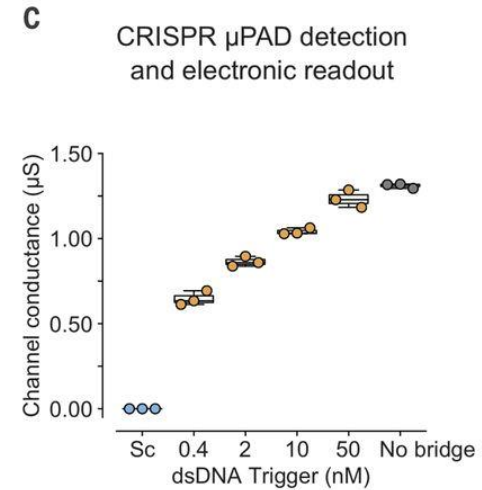
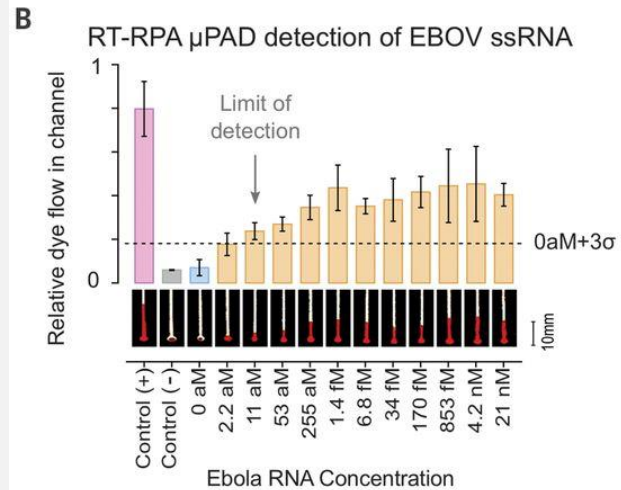
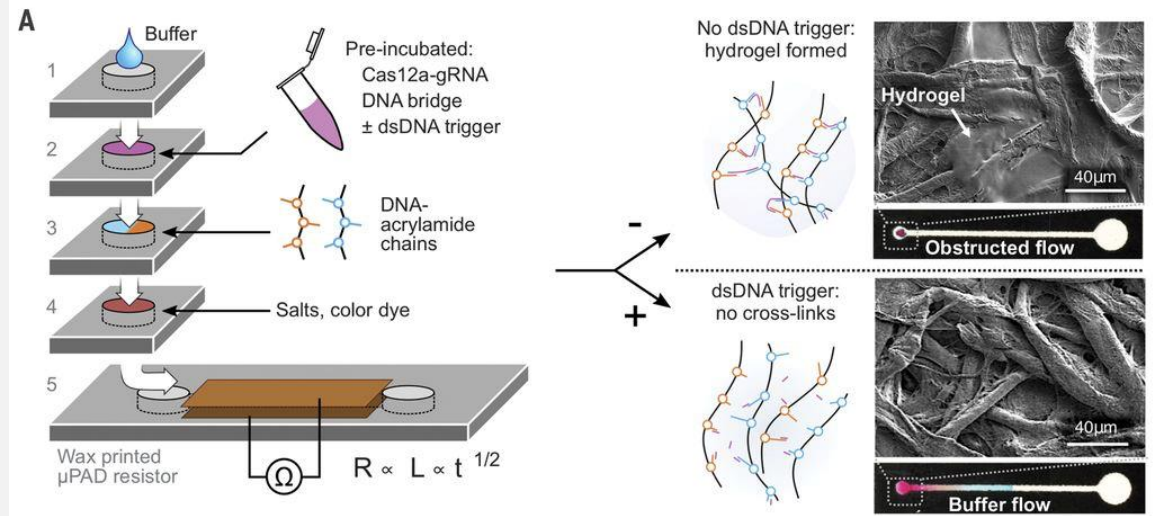

Omia esimerkkejä solujen muokkauksesta

Thymidylate synthase disruption to limit cell proliferation in cell therapies

Rocio Sartori-Maldonado, Hossam Montaser, Inkeri Soppa, Solja Eurola, Melanie Balaz, Henri Puttonen,

Timo Otonkoski, Jonna Saarimäki-Vire, Kirmo Wartiovaara

doi: <https://doi.org/10.1101/2023.06.26.546441>

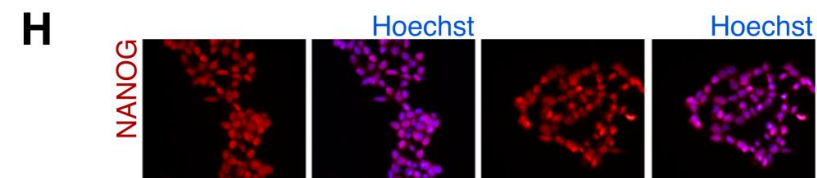
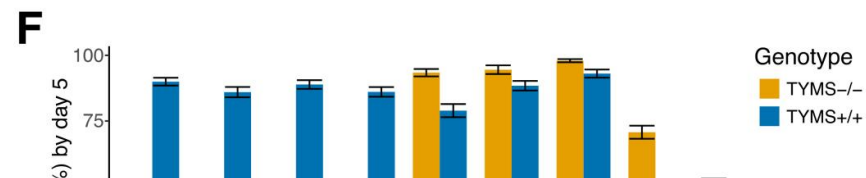
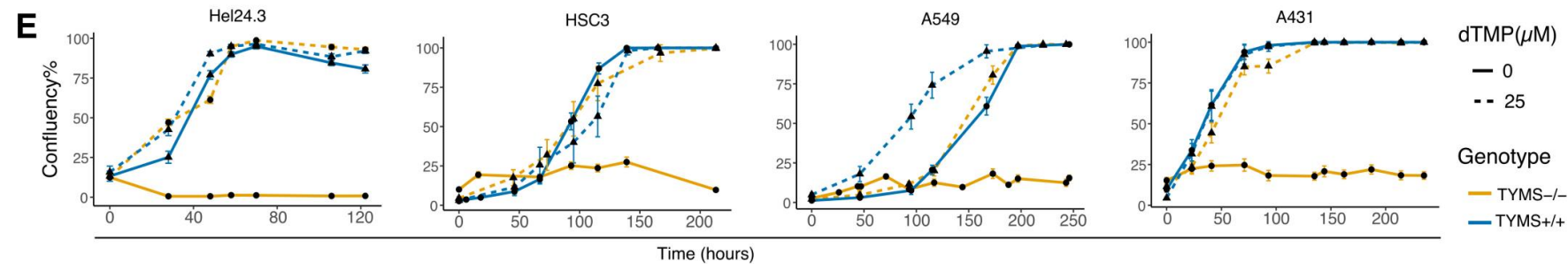
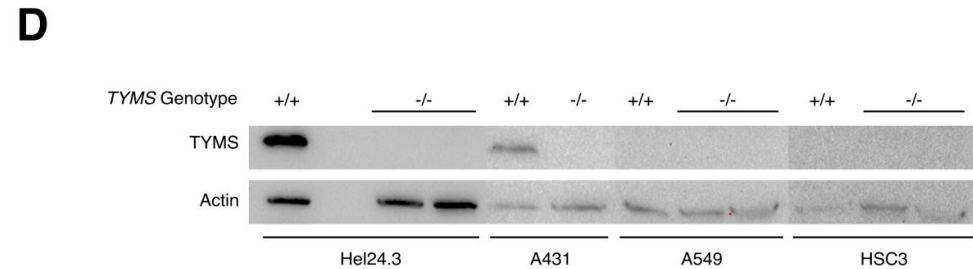
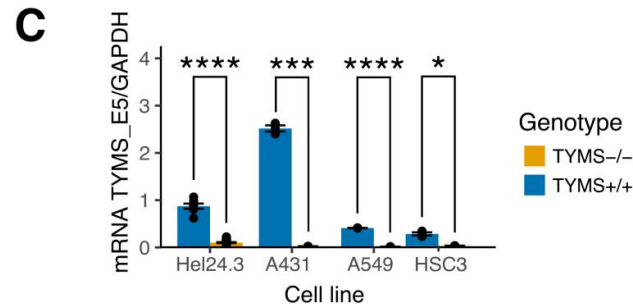
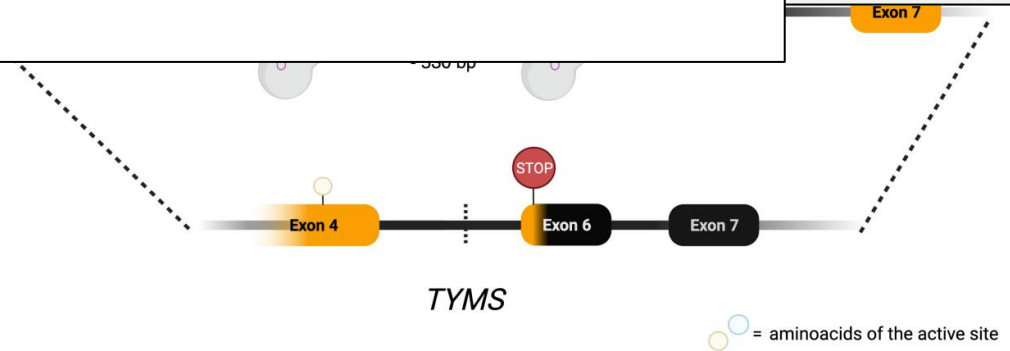
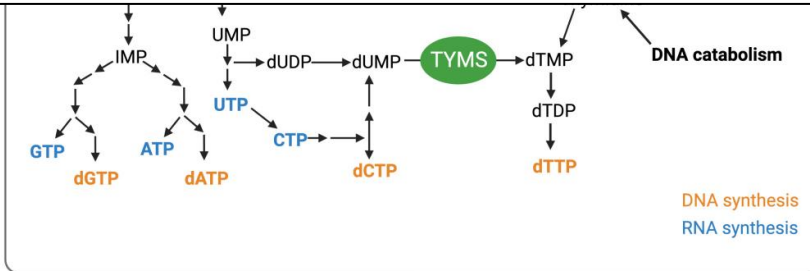

TYMS^{-/-} cell differentiation

G

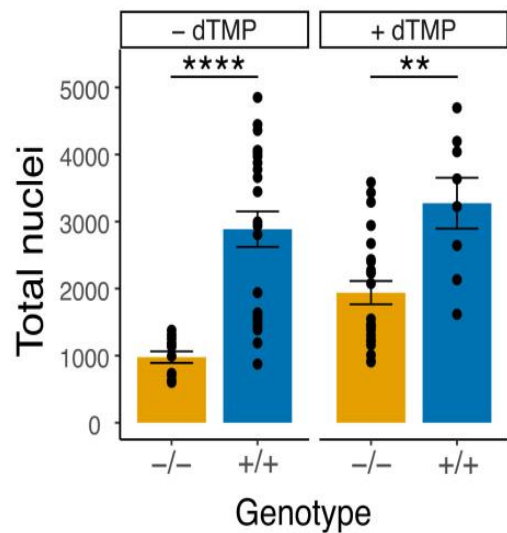

J

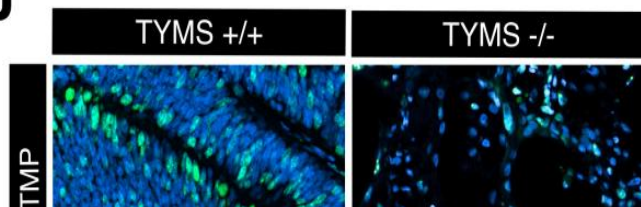

K

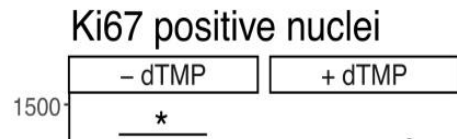

H

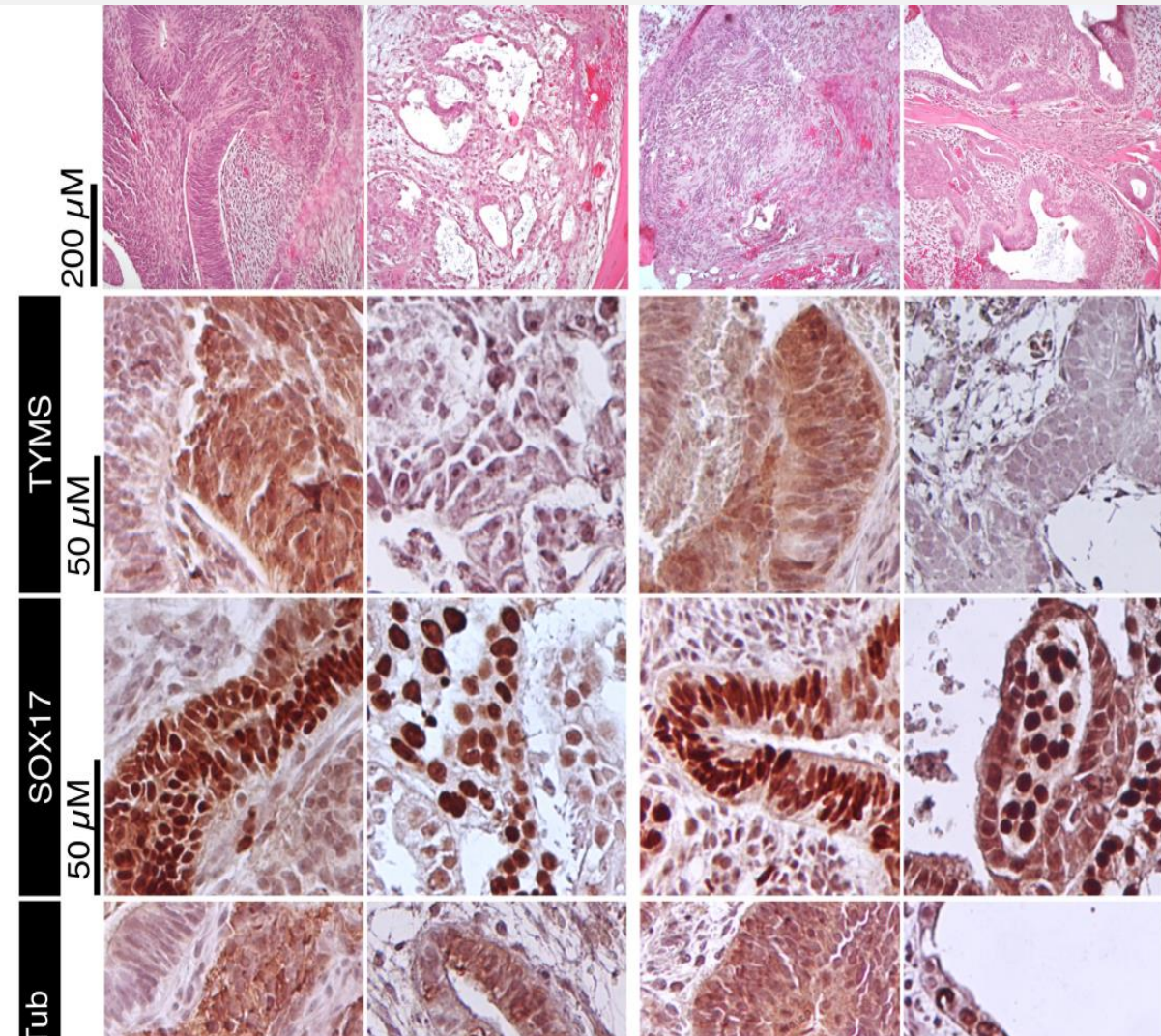

Making beta cells

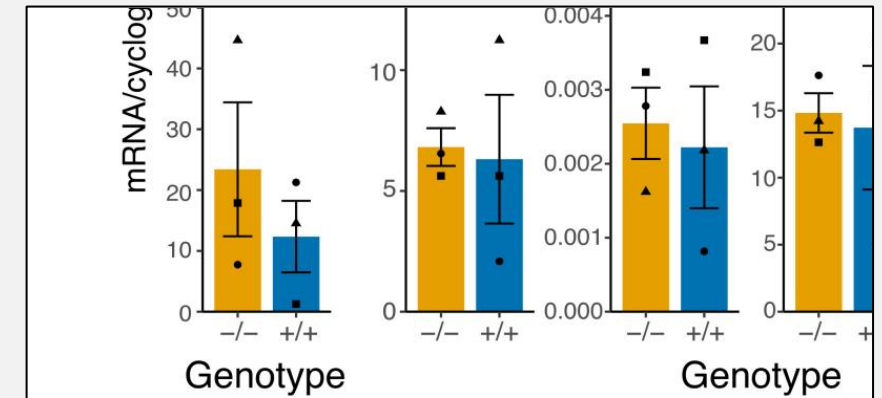
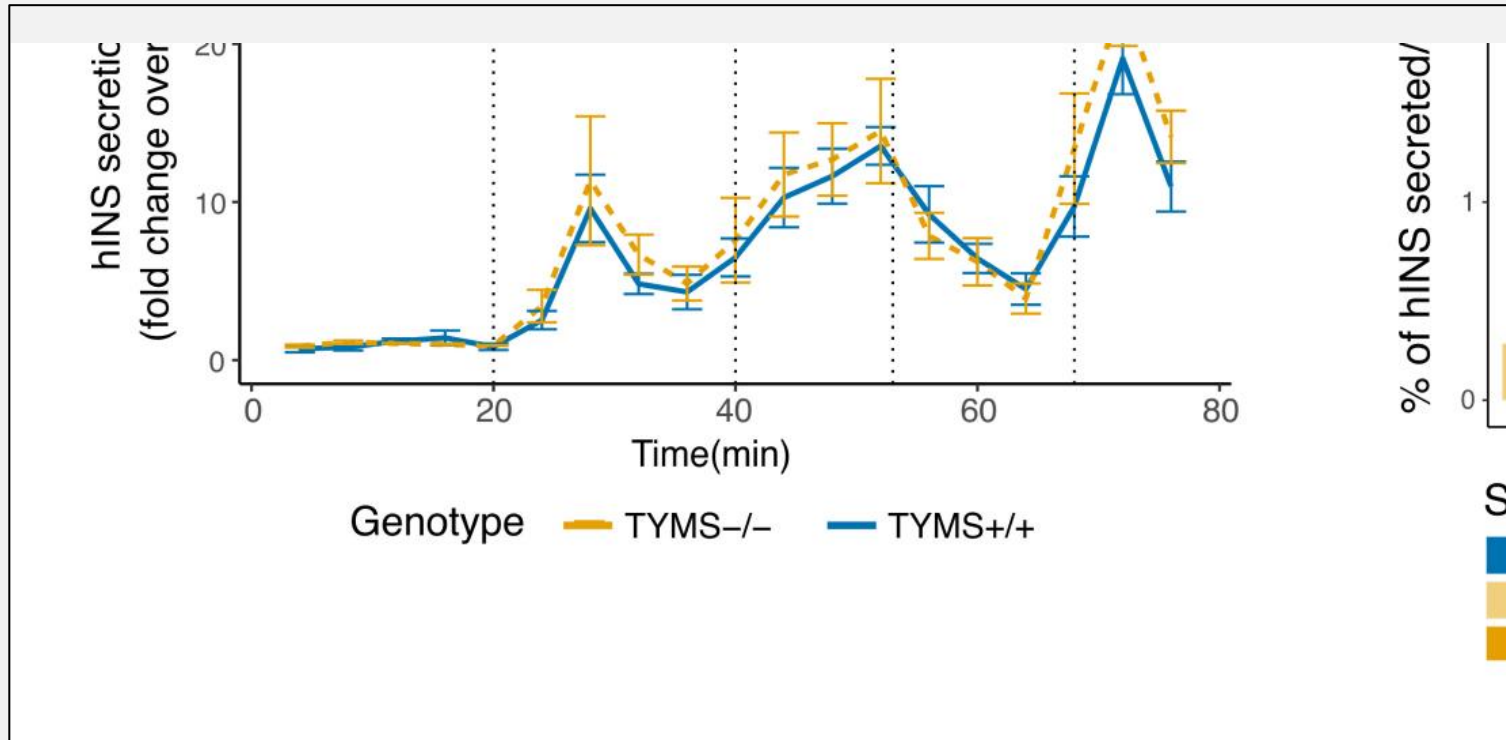

D

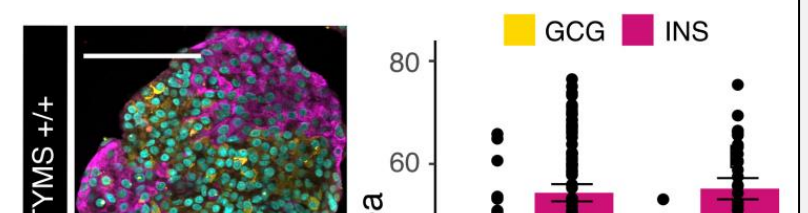

TYMS^{-/-} beta cell function

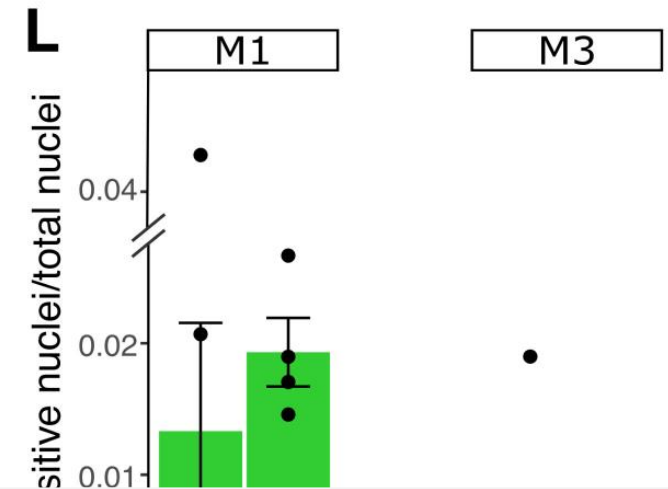
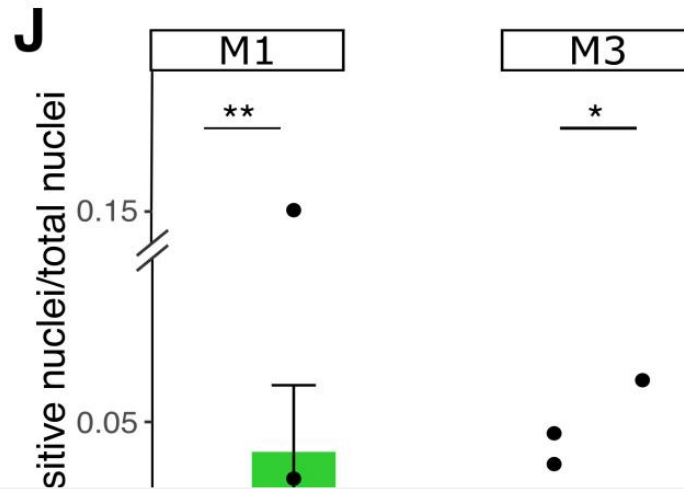
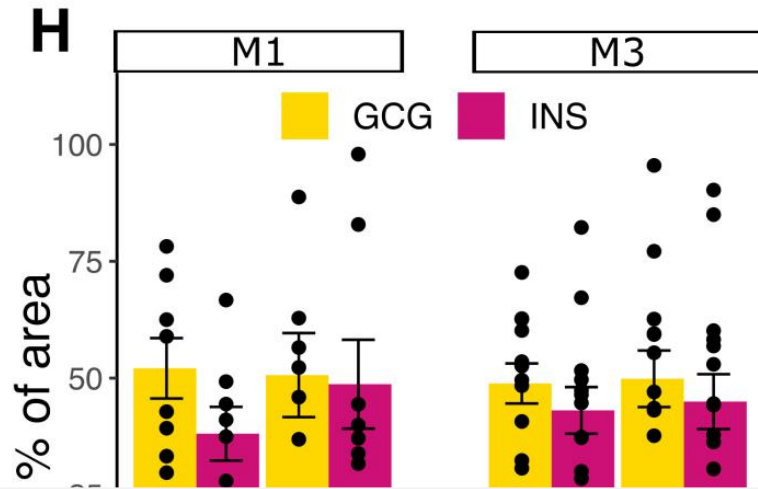
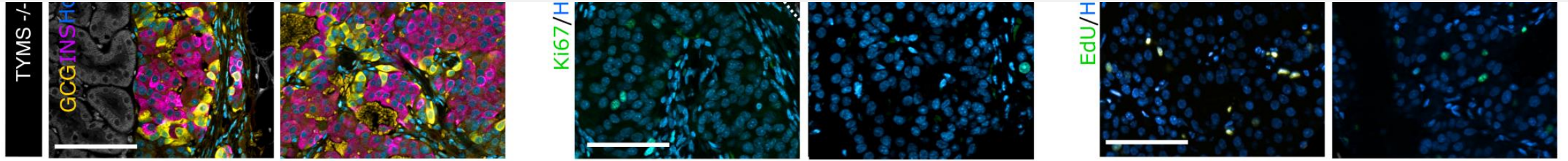

Geenin levitys

Lipid RNA
CRISPR particle

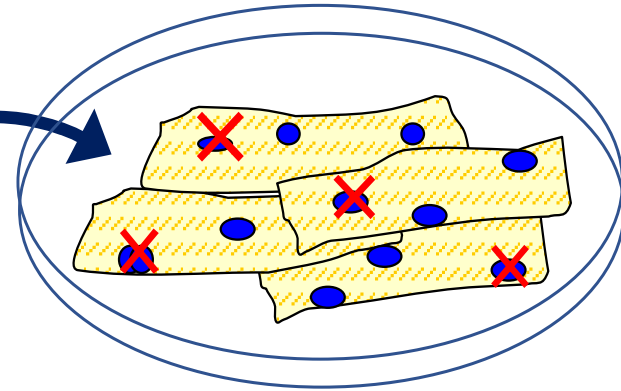
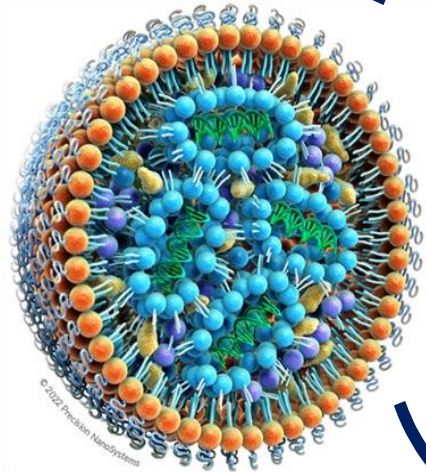

Malfunctioning patient
cells with gene mutation

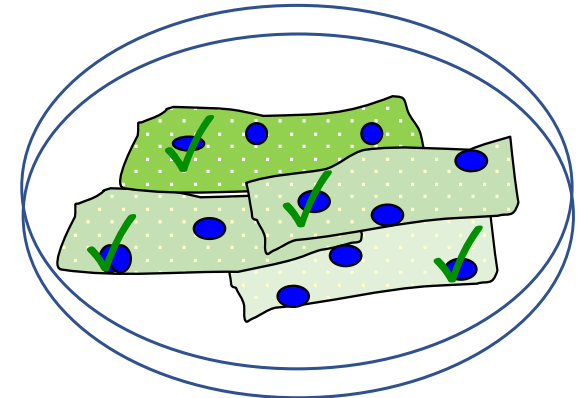

Genetically corrected
functional cells

Mouse disease model

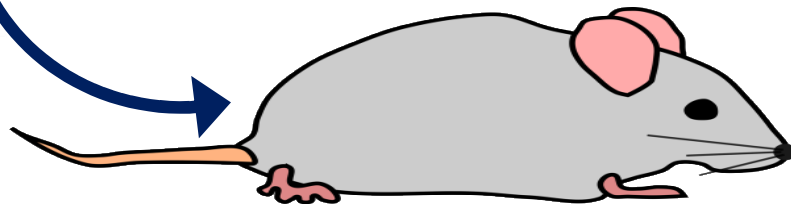

Genetically corrected
functional tissues

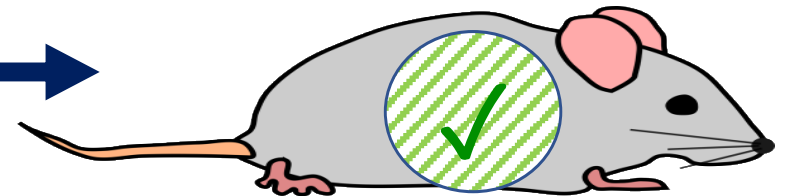

On target activity

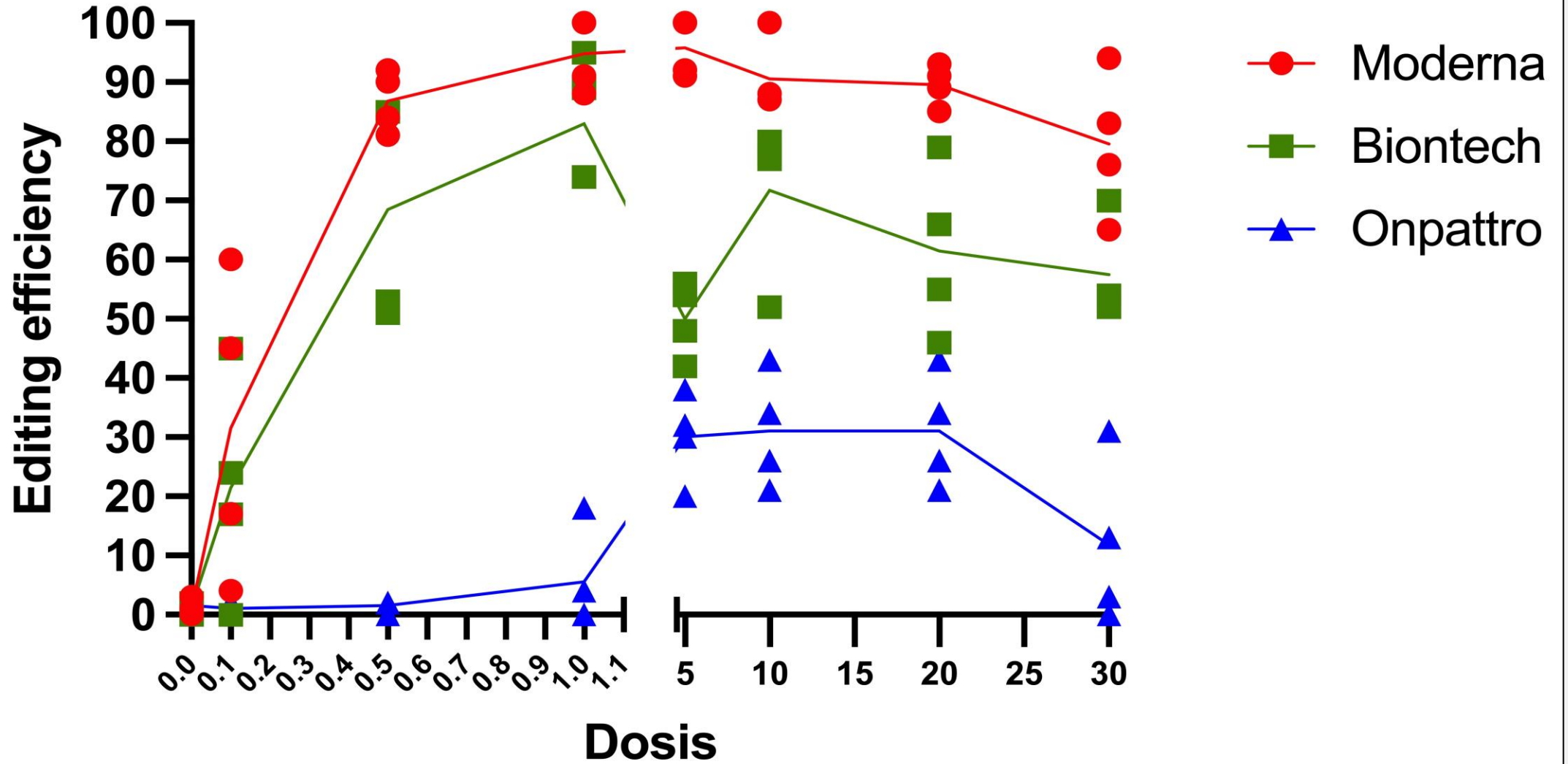

DNA-osaamista
tarvitaan paljon
biologian
ulkopuolella

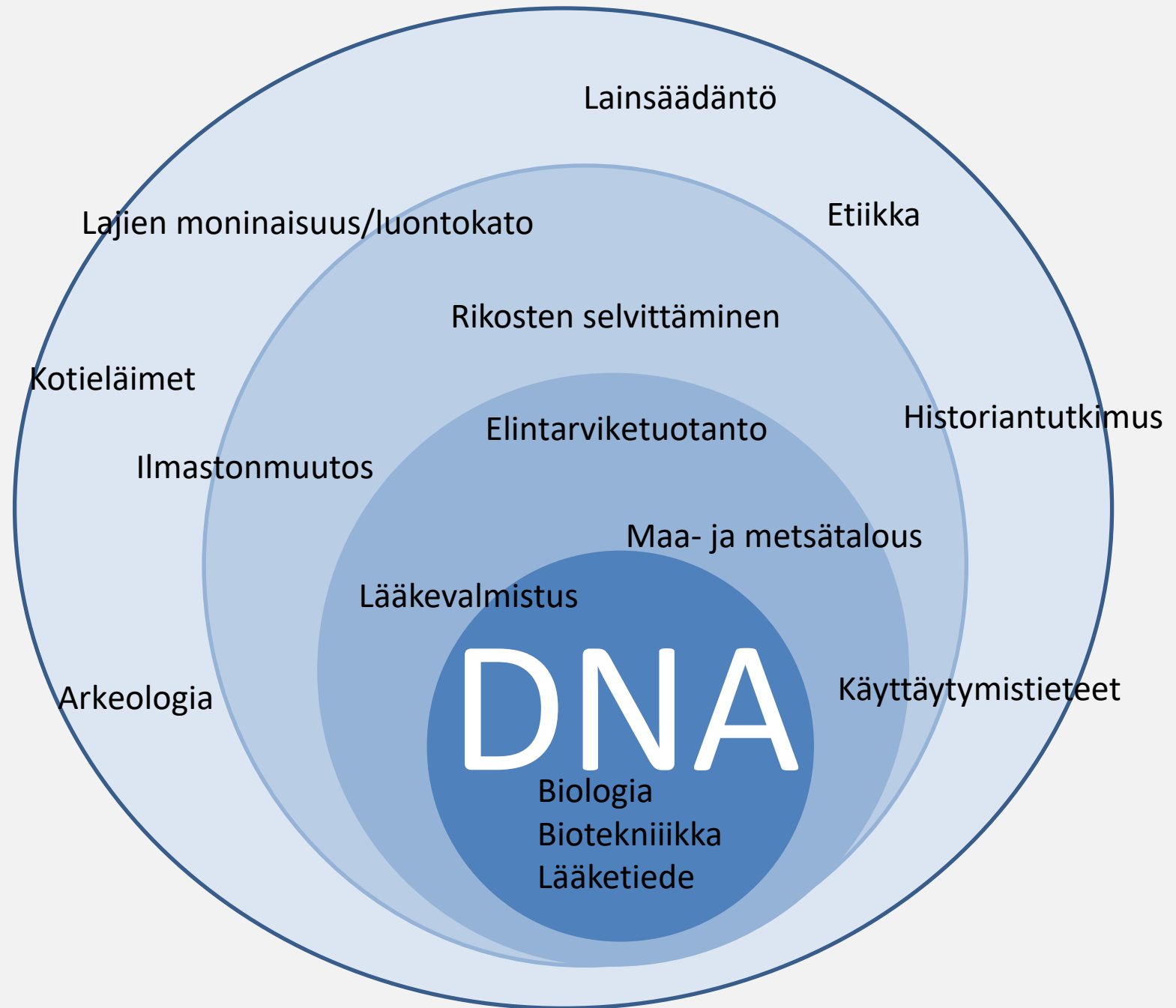

Toiveita luennoille:

- mitä menetelmiä oikeasti käytetään, mihin tarkoitukseen ja miten
- mihin crispriä käytetään
- mitä dna-siruilla tehdään, vai onko sekvensointi jo korvannut ne
- geenitekniikan lääketieteelliset sovellukset, geenihoito
- mitä kuuluu kantasolututkimukselle

BIOL6: DNA:n muokkaus ja tutkiminen geenitekniikalla, Biotekniikan keskeiset sovellukset ja merkitys

Kiitos mielenkiinnosta!

