

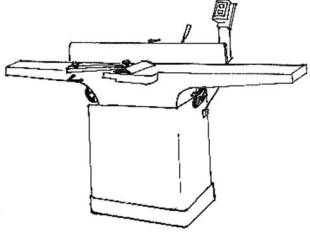

Nimeä työkonet. Tehtävän alaosassa apuna työkonien nimet.

			
V:	V:	V:	V:
			
V:	V:	V:	V:
			
V:	V:	V:	V:
			
V:	V:	V:	V:
			
V:	V:	V:	V:
	<p>Oikohöylä – Tasohöylä – Vannesaha – Puusorvi – Ahjo Tarkkuussirkkeli – Katkaisusaha – Penkkihiomakone Kanttikone – Hitsauskone – Nauhihiomakone – Kaarisakset Pylväsporakone – Pistehitsauskone – Kiillotuskone Kulmahiomakone – Laserleikkuri – Konelehtisaha Pistosaha – Akkuporakone – 3D-tulostin</p>		
V:			

Nimeä työkonet. Tehtävän alaosassa apuna työkonien nimet.
VASTAUKSET

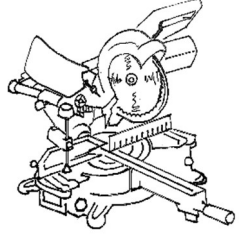
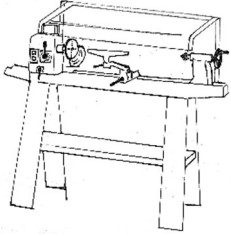
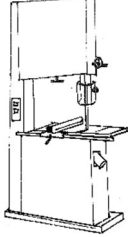
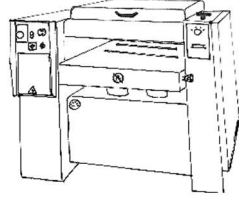
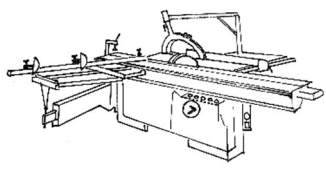
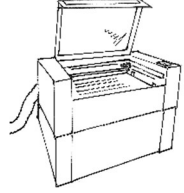
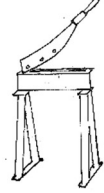
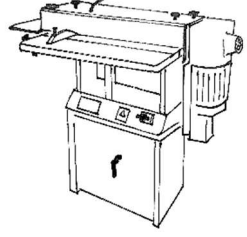
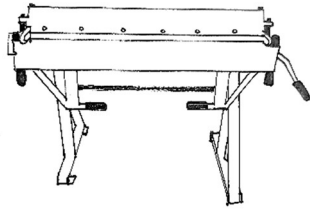

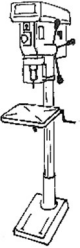
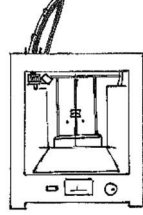
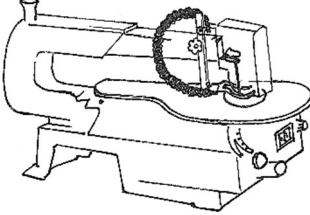
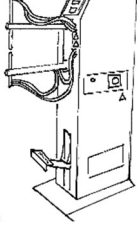
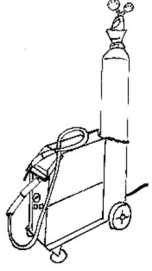
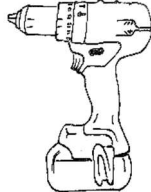
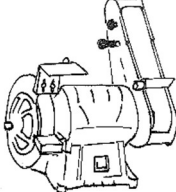
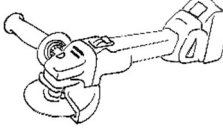
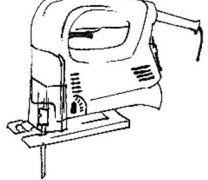
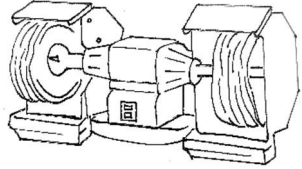
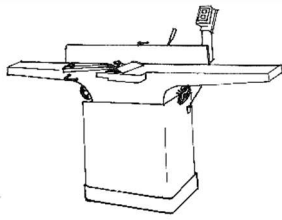
V: Oikohöylä

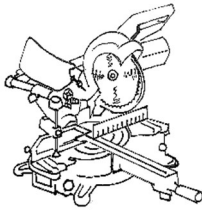

V: Katkaisusaha

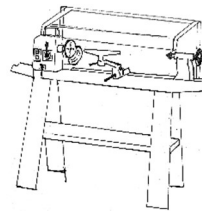

V: Puusorvi

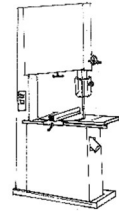

V: Vannesaha

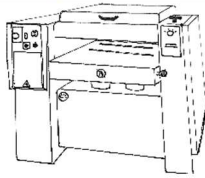

V: Tasohöylä

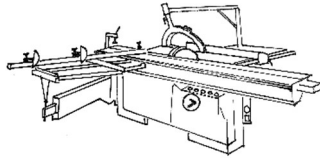

V: Tarkkuussirkkeli



V: Laserleikkuri



V: Kaarisakset

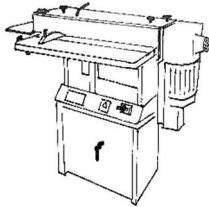

V: Nauhahiomakone

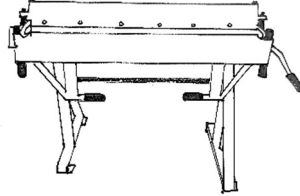

V: Kanttikone

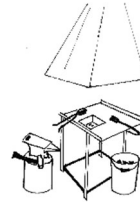

V: Ahjo



V: Pylväsporakone

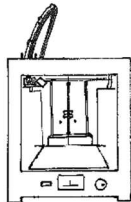

V: 3D-tulostin

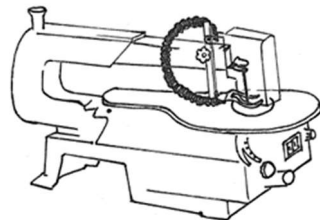

V: Konelehtisaha

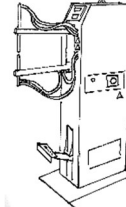

V: Pistehitsauskone

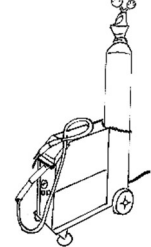

V: Hitsauskone

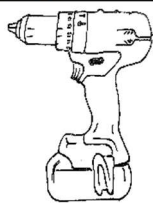

V: Akkuporakone

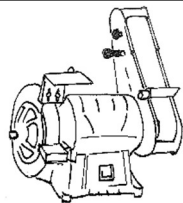

V: Penkkihiomakone

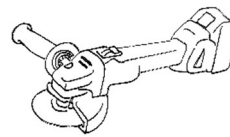

V: Kulmahiomakone

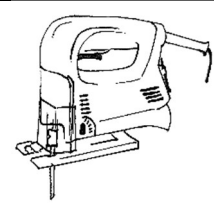

V: Pistosaha

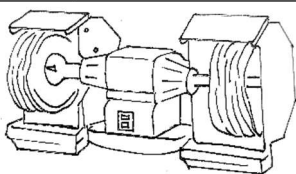

V: Kiillotuskone

Oikohöylä – Tasohöylä – Vannesaha – Puusorvi – Ahjo
 Tarkkuussirkkeli – Katkaisusaha – Penkkihiomakone
 Kanttikone – Hitsauskone – Nauhahiomakone – Kaarisakset
 Pylväsporakone – Pistehitsauskone – Kiillotuskone
 Kulmahiomakone – Laserleikkuri – Konelehtisaha
 Pistosaha – Akkuporakone – 3D-tulostin